

# On families of fibred knots with equal Seifert forms

FILIP MISEV

For every genus  $g \geq 2$ , we construct an infinite family of strongly quasipositive fibred knots  $K_n$  having the same Seifert form as the torus knot  $T(2, 2g + 1)$ . In particular, their homological monodromies agree and their signatures and four-genera are maximal:  $|\sigma(K_n)| = 2g_4(K_n) = 2g$ . On the other hand, the geometric stretching factors are pairwise distinct and the knots are pairwise not ribbon concordant.

## 1. Introduction and summary of results

Strongly quasipositive fibred links arise as particular intersections of complex plane curves with the unit sphere  $S^3 \subset \mathbb{C}^2$ . Examples include the classical links of plane curve singularities (among which are the torus links  $T(n, m)$  for positive  $n, m$ ), but many more links such as closures of positive braids fall into this family.

A recent note by Baker [4] draws attention to this rich albeit very special family of links, in the context of knot concordance. Two knots  $K_0, K_1 \subset S^3$  are said to be *concordant* if there exists a smooth embedding  $A : S^1 \times [0, 1] \hookrightarrow S^3 \times [0, 1]$  such that  $A(S^1 \times \{i\}) = K_i \times \{i\}$ ,  $i = 0, 1$ . Knots in  $S^3 = \partial B^4$  which are concordant to the unknot are called *slice*. They are given by slicing the four-ball  $B^4$  along a disc (obtained by capping off the unknotted boundary component of a concordance annulus). A slicing disc  $(D^2, \partial D^2) \subset (B^4, S^3)$  is called a *ribbon* disc, if the distance function to  $0 \in B^4$  is a Morse function on  $D^2$  without interior local maxima. Accordingly, knots bounding a ribbon disc are called *ribbon*. The still unsettled *slice-ribbon* question posed by Fox in the 60s is whether every slice knot is ribbon [15]. Baker proved that two strongly quasipositive fibred knots  $K_0, K_1$  must be equal if  $K_0 \# (-K_1)$  is a ribbon knot [4]. In view of Fox's question, Baker's observation leads to two equally intriguing alternative statements: either there exists a fibred

---

The author is supported by the Swiss National Science Foundation (#168676).

knot of the form  $K_0 \# (-K_1)$  which is slice but not ribbon, or every knot concordance class contains at most one strongly quasipositive fibred knot.

We describe a simple and general construction proposed by Baader (compare [1]), which gives rise to infinite families of strongly quasipositive fibred knots having the same Seifert form. In particular, classical knot concordance invariants whose definition is based on the Seifert form, such as the Levine-Tristram signatures, fail to distinguish these knots. As a special case in which it is relatively easy to study the constructed knots in some detail, we obtain the following theorem.

**Theorem 1.** *Let  $g \geq 2$ . There exists an infinite family of (pairwise non-isotopic) genus  $g$  knots  $K_n \subset S^3$ ,  $n \in \mathbb{N}$ , such that for all  $n \in \mathbb{N}$*

- 1)  $K_n$  is strongly quasipositive, fibred and hyperbolic,
- 2)  $K_n$  has the same Seifert form as the torus knot  $T(2, 2g + 1)$ .

To distinguish the constructed knots, we study their monodromies, which turn out to be pseudo-Anosov, and compare their geometric stretching factors. The following corollary is an immediate consequence.

**Corollary 1.** *Let  $g \geq 2$ . There exist infinitely many hyperbolic strongly quasipositive fibred knots of genus  $g$ , having*

- 1) maximal signature,
- 2) periodic homological monodromy,
- 3) isomorphic Alexander modules.

Families of fibred knots with equal Seifert forms have been studied before in connection with (ribbon) concordance. For example, Bonahon used Stallings twists to construct a family of fibred genus two knots  $K_n$ ,  $n \in \mathbb{N}$ , whose homological monodromies are pairwise conjugate and such that  $K_n \# (-K_m)$  is not a ribbon knot for  $n \neq m$  (compare [9], see also [10]). However, these knots are not strongly quasipositive. In fact, a quasipositive surface cannot contain an essential zero-framed annulus [36], which is required for a Stallings twist. To prove that the knots  $K_n \# (-K_m)$  are not ribbon, Bonahon applied the following criterion of Casson and Gordon [11, Theorem 5.1].

*A fibred knot in a homology 3-sphere is homotopically ribbon if and only if its closed monodromy extends over a handlebody.*

The notion of a knot being homotopically ribbon is a weakened version of ribbonness introduced by Casson and Gordon. If  $S$  is a compact orientable surface with boundary, a diffeomorphism  $\varphi : S \rightarrow S$  (fixing the boundary of  $S$  pointwise) is said to extend over a handlebody if and only if there exists a three-dimensional handlebody  $W$  such that  $S \subset \partial W$ ,  $\partial W \setminus S$  is a union of discs, and  $\varphi$  is the restriction of a diffeomorphism of  $W$ .

**Proposition 1.** *Let  $K_n$ ,  $n \in \mathbb{N}$ , be the family of knots constructed in the proof of Theorem 1. The following holds for all  $i, j \in \mathbb{N}$ ,  $i \neq j$ .*

- 1)  $K_i$  and  $K_j$  are not ribbon concordant,
- 2)  $K_i$  and  $K_j$  are not homotopy ribbon concordant,
- 3) the closed monodromy of  $K_i \# (-K_j)$  does not extend over a handlebody,
- 4) the smooth four-ball genus of  $K_i \# (-K_j)$  is at most one.

Besides their implication in the slice-ribbon problem, strongly quasi-positive fibred links also appear in the context of the *L-space conjecture* due to Boyer, Gordon and Watson [7]. L-spaces are 3-manifolds with minimal Heegaard Floer homology, including lens spaces as particular examples. The L-space conjecture suggests that L-spaces are exactly those irreducible  $\mathbb{Q}$ -homology spheres whose fundamental groups do not support any left-invariant strict total order. Knots which admit a Dehn surgery to an L-space are called *L-space knots*. By combined work of Hedden, Ghiggini, Ni and Ozsváth and Szabó, all L-space knots are known to be strongly quasi-positive and fibred (see [19, Theorem 1.2], [17], [26, Corollary 1.3], [27] and [29, Corollary 1.6]). Boileau, Boyer and Gordon recently studied knots which give rise to L-spaces both by Dehn surgery and by taking a cyclic branched covering [6]. They deduce strong restrictions on such knots: the signature must be maximal and the Alexander polynomial is a product of cyclotomic polynomials. Further they show that the degree of an L-space branched covering of such a knot is at most five. If it is four or five, the knot must be the trefoil; if it is three, the knot is either the trefoil, the  $T(2, 5)$  torus knot or a hyperbolic knot with the same Alexander polynomial as  $T(2, 5)$  (see [6, Corollary 1.4]). This leads naturally to the following question.

**Question.** Are any of the knots  $K_n$ ,  $n \neq 0$ , constructed in the proof of Theorem 1 L-space knots? Are any of the associated double or triple branched covers L-spaces (for  $g = 2$ )?

In a project with Gilberto Spano we address the first part of this question and show that none of the knots  $K_n$ ,  $n \neq 0$ , is an L-space knot [24].

## 2. Preliminaries

### 2.1. Knots, links, Seifert surfaces and Seifert forms

By a *knot* we understand an oriented smoothly embedded circle in the three-dimensional sphere  $S^3$ , considered up to ambient isotopy. Similarly, a *link* is a disjoint union of several oriented circles embedded in  $S^3$ , considered up to ambient isotopy. Given a link  $L$ , a *Seifert surface* for  $L$  is a compact connected oriented embedded surface  $S \subset S^3$  whose boundary (with the induced orientation) is  $L$ . Just as for knots and links, Seifert surfaces related by an ambient isotopy are considered equivalent. The genus of a knot, denoted  $g(K)$ , is the smallest genus of all Seifert surfaces for  $L$ . Similarly, the *smooth four-genus*, or *slice genus*,  $g_4(K)$  is the smallest genus of a smooth, compact, properly embedded surface in the four-ball  $B^4$  which bounds  $K$ . Since the interior of any Seifert surface in  $S^3 = \partial B^4$  can be pushed inside  $B^4$ , the inequality  $g_4(K) \leq g(K)$  holds for every knot  $K$ .

The *Seifert form* of a Seifert surface  $S$  is a bilinear form

$$V : H_1(S, \mathbb{Z}) \times H_1(S, \mathbb{Z}) \rightarrow \mathbb{Z}.$$

On homology classes  $a, b \in H_1(S, \mathbb{Z})$  of oriented simple closed curves  $\alpha, \beta \subset S$ , the value of  $V$  is defined to be  $V(a, b) = \text{lk}(\alpha, \beta^+)$ , where the curve  $\beta^+ \in S^3 \setminus S$  is obtained by pushing  $\beta$  slightly off  $S$  in the positive normal direction given by the orientation of  $S$ , and  $\text{lk}$  denotes the linking number of a pair of disjoint oriented knots in  $S^3$ . This is well-defined and determines  $V$  by linear extension to  $H_1(S, \mathbb{Z})$ .

The *signature* of a knot  $K$ , denoted  $\sigma(K)$ , is defined as the number of positive eigenvalues minus the number of negative eigenvalues of  $V + V^T$ , where  $V$  is the Seifert form of a Seifert surface  $S$  for  $K$ . It is independent of the choice of  $S$ . The signature descends to a group homomorphism from the knot concordance group (knots modulo concordance with connected sum as group multiplication) to the integers. Its absolute value gives a lower bound on twice the slice genus of a knot:  $|\sigma(K)| \leq 2g_4(K)$  for every knot  $K$  (see [25, Theorem 9.1]). A knot  $K$  is said to have *maximal signature* if  $|\sigma(K)| = 2g_4(K) = 2g(K)$ .

## 2.2. Fibred links, Hopf plumbing and monodromy

A link  $L$  is *fibred* if its complement  $S^3 \setminus L$  has the structure of a surface bundle over  $S^1$  such that each fiber is the interior of a Seifert surface for  $L$ . Seifert surfaces arising as the fibres of such fibrations are called *fibre surfaces*. They come with a characteristic mapping class called the *monodromy*, whose mapping torus gives back the fibre bundle. Once the embedding of a fibre surface into  $S^3$  is fixed, its monodromy map is determined up to isotopy; without specifying the embedding, it is well-defined up to isotopy and conjugacy. Since a fibred link has a unique Seifert surface of minimal genus and fibre surfaces are minimal genus surfaces [38, Proposition 2.19] (see also [12, Lemma 5.1]), there is a bijective correspondence between fibre surfaces and fibred links. Note that monodromy maps are subject to Nielsen and Thurston's classification of surface mapping classes into periodic, pseudo-Anosov and reducible mapping classes [14, 42].

Examples of fibred links prominently appear in singularity theory as transverse intersections of an algebraic curve  $C \subset \mathbb{C}^2$  with a small sphere centered at an isolated singular point [23]. These include the torus links  $T(n, m)$  for  $n, m \in \mathbb{N}$ , given by the singularity at  $(0, 0)$  of the curve  $\{(x, y) \in \mathbb{C}^2 \mid x^n - y^m = 0\}$ . The monodromy of a torus link is a periodic mapping class (see for example [23, Lemma 9.4]). In the simplest non-trivial case  $T(2, 2)$ , the corresponding fibre surface is a so-called *Hopf band*, an embedded annulus with one full twist.

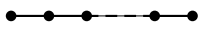
Given a fibre surface  $S$  and a Hopf band  $H$  which are contained in disjoint balls and thus unlinked in  $S^3$ , and a properly embedded interval  $\gamma \subset S$ , we can glue  $H$  to  $S$  along  $\gamma$  to obtain a new Seifert surface  $S *_\gamma H$ . On the level of abstract (non-embedded) surfaces, this corresponds to a 1-handle attachment along  $\partial\gamma$  to  $S$ . The resulting Seifert surface  $S *_\gamma H$  is said to be obtained by *plumbing*  $H$  onto  $S$  along  $\gamma$ . It was observed by Stallings [40] that this surface is again a fibre surface, and its monodromy is the composition of the monodromy of  $S$  (extended to  $S *_\gamma H$  by the identity) with a positive Dehn twist along the core circle of  $H$ . Torus link fibre surfaces are instances of fibre surfaces which can be obtained from a disc by iterated plumbing of Hopf bands. For example the fibre surface of the torus link  $T(2, n+1)$ ,  $n \in \mathbb{N}$ , is obtained by plumbing  $n$  Hopf bands in such a way that the intersection graph of their core circles is the line graph  with  $n$  vertices.

### 2.3. Strongly quasipositive links

Quasipositive and strongly quasipositive braids and links were introduced and studied by Rudolph [34].

A link  $L \subset S^3$  is *quasipositive* if and only if it can be obtained as transverse intersection of a complex algebraic curve with the unit sphere  $S^3 \subset \mathbb{C}^2$ , a result by Boileau and Orevkov [8] and Rudolph [32]. In terms of braids, quasipositive links are represented by products of conjugates of the positive standard generators  $\sigma_1, \sigma_2, \dots$  of the braid group:  $L$  is quasipositive if there exists a braid  $\beta$  of the form

$$\beta = \prod_{i=1}^d w_i \sigma_{n_i} w_i^{-1},$$

for some  $d, n_1, \dots, n_d \in \mathbb{N}$ , where the  $w_i$  are elements of the braid group, such that  $L$  is obtained by standard braid closure of  $\beta$ . If in addition each conjugating word  $w_i$  has the particular form

$$w_i = \sigma_{n_i-k} \cdots \sigma_{n_i-1},$$

for some  $k$  (depending on  $i$ ), the braid  $\beta$  and its closure are called *strongly quasipositive*. Strongly quasipositive links generalise links of singularities, positive braid closures, and positive links [35]. They are characterised as the boundaries of incompressible subsurfaces of positive torus link fibres [33], form a rather large class of links representing every possible Seifert form [31, §3] and behave naturally with respect to fibredness: connected sum, plumbing and positive cabling preserve strong quasipositivity [20, 34].

### 2.4. Dilatation of pseudo-Anosov multi-twists

We briefly review a classical construction due to Thurston [42] (see also [14, Exposé 13, §III]) which allows to compute the dilatation of a surface mapping class which is given by two multi-twists. It will be used to estimate the dilatation of the monodromies to be constructed in the proof of Theorem 1.

Let  $S$  be a compact connected oriented surface. A *multi-curve* is a finite union of pairwise disjoint essential simple closed curves in  $S$ . Let  $\underline{\alpha} = \alpha_1 \dot{\cup} \cdots \dot{\cup} \alpha_n$  and  $\underline{\beta} = \beta_1 \dot{\cup} \cdots \dot{\cup} \beta_m$  be two multi-curves with the following properties.

- $\underline{\alpha}$  and  $\underline{\beta}$  intersect transversely,

- their union  $\underline{\alpha} \cup \underline{\beta}$  is connected,
- $\underline{\alpha}$  and  $\underline{\beta}$  are *tight*, that is, the number of intersections between  $\alpha_i$  and  $\beta_j$  (counted without sign) is minimal among all pairs of curves respectively isotopic to  $\alpha_i$  and  $\beta_j$ , for all  $i, j$ ,
- $\underline{\alpha}$  and  $\underline{\beta}$  *fill up*  $S$ , that is,  $S \setminus (\underline{\alpha} \cup \underline{\beta})$  consists of discs and boundary parallel annuli.

Let  $\varphi : S \rightarrow S$  be given as the composition of right Dehn twists along the curves  $\alpha_i$ , followed by right Dehn twists along the curves  $\beta_j$ :

$$\varphi = t_{\beta_m} \circ \dots \circ t_{\beta_1} \circ t_{\alpha_n} \circ \dots \circ t_{\alpha_1}.$$

View the surface  $S$  as a union of Euclidean rectangular charts of the form  $R_p \cong [0, w_j] \times [0, h_i] \subset \mathbb{R}^2$ , one for each  $p \in \alpha_i \cap \beta_j$ , for all  $i, j$ , whose horizontal and vertical axes  $[0, w_j] \times \{\frac{1}{2}h_i\}$  and  $\{\frac{1}{2}w_j\} \times [0, h_i]$  correspond to the intersection of  $R_p \subset S$  with  $\alpha_i$  and  $\beta_j$ , respectively. The widths and heights  $w_j, h_i$  are chosen such that the rectangles fit nicely together along their sides to form annular neighbourhoods of the  $\underline{\alpha}$ - and  $\underline{\beta}$ -curves. With respect to the charts  $R_p$ , the Dehn twists  $t_{\alpha_i}$  and  $t_{\beta_j}$  are given by linear shearing maps. The last step consists in choosing the  $w_j$  and  $h_i$  carefully, such that the amount of shearing is the same on every rectangle. To this end, consider the  $n \times m$  matrix  $N$  whose entry  $N_{ij}$  is the geometric intersection number of  $\alpha_i$  and  $\beta_j$ . The connectedness of  $\underline{\alpha} \cup \underline{\beta}$  implies that some power of the matrix  $NN^T$  has strictly positive entries. Therefore,  $NN^T$  has an eigenvector  $h$  with strictly positive entries for the Perron-Frobenius eigenvalue  $\mu > 0$ :  $NN^T h = \mu h$ . The vector  $w = \mu^{-\frac{1}{2}} N^T h$  is then an eigenvector of  $N^T N$  to the same eigenvalue:  $N^T N w = \mu w$ . In choosing the widths and heights of the  $R_p$  as the components of  $w$  and  $h$ , respectively, it is achieved that the neighbourhood  $\bigcup_{p \in \alpha_i \cap \beta_j} R_p$  of  $\alpha_i$  is a cylinder of height  $h_i$  and circumference

$$\sum_{\{(p,j) \mid p \in \alpha_i \cap \beta_j\}} w_j = (Nw)_i = \mu^{-\frac{1}{2}} (NN^T h)_i = \mu^{\frac{1}{2}} h_i.$$

Therefore, the matrices of the Dehn twists  $t_{\alpha_i}$  and  $t_{\beta_j}$ , written in the standard basis of  $\mathbb{R}^2 \supset R_p$ , do not depend on  $i, j$ :

$$T_{\underline{\alpha}} = \begin{bmatrix} 1 & \mu^{1/2} \\ 0 & 1 \end{bmatrix}, \quad T_{\underline{\beta}} = \begin{bmatrix} 1 & 0 \\ -\mu^{1/2} & 1 \end{bmatrix}$$

Thus,  $\varphi$  restricts on each  $R_p$  to the linear map  $T_{\underline{\beta}} \circ T_{\underline{\alpha}}$ , whose eigendirections define two transverse invariant foliations on  $\bar{S}$  with singularities at the

corners of the rectangles  $R_p$  and whose eigenvalues  $\lambda^{\pm 1}$  are the stretching factors of  $\varphi$ .

### 3. Families of fibred knots

We first describe an explicit construction of a family of knots  $K_n$ ,  $n \in \mathbb{N}$ , having the properties stated in Theorem 1. To prove that the knots are indeed pairwise nonisotopic, we compute the geometric dilatation  $\lambda_n \in \mathbb{R}$  of the monodromy of  $K_n$ . For this purpose, we choose the construction in such a way that the monodromy is represented by a composition of two multi-twists, that is, products of Dehn twists on sets of disjoint curves.

*Proof of Theorem 1 – Construction of the knots  $K_n$ .* Let  $S \subset S^3$  be the fibre surface of the  $T(2, 2g)$  torus link, viewed as a plumbing of  $2g - 1$  positive Hopf bands  $H_1, \dots, H_{2g-1}$  according to the tree  $\bullet \text{---} \bullet \text{---} \bullet \text{---} \bullet \text{---} \bullet$ . We choose the plumbing order as follows. First let  $S' = H_1 \# \dots \# H_g$  be the connected sum of the first  $g$  bands. The monodromy of  $S'$  is a composition of positive Dehn twists along  $g$  pairwise disjoint simple closed curves, namely the core curves  $\alpha_1, \dots, \alpha_g$  of  $H_1, \dots, H_g$ . Denote  $\beta_1, \dots, \beta_{g-1}$  the cores of the remaining Hopf bands  $H_{g+1}, \dots, H_{2g-1}$ , respectively. The latter may now be plumbed to  $S'$  from below such that  $\alpha_1, \beta_1, \alpha_2, \beta_2, \dots, \alpha_{g-1}, \beta_{g-1}, \alpha_g$  form a chain, that is,  $\beta_i$  intersects each of its neighbours  $\alpha_i$  and  $\alpha_{i+1}$  transversely in one point (for all  $i = 1, \dots, g - 1$ ), and there are no other intersections (see Figure 1). Denote  $S$  the resulting surface, which is indeed the fibre sur-

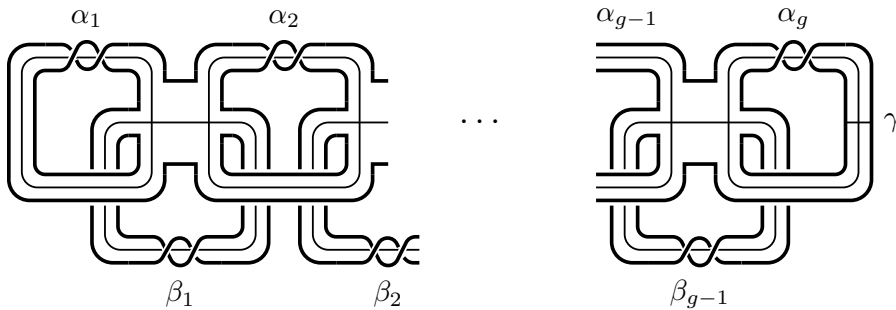

Figure 1: The fibre surface  $S$  of the torus link  $T(2, 2g)$  and core curves of the plumbed Hopf bands.

face of  $T(2, 2g)$ . Now let  $\gamma \subset H_{2g-1} \subset S$  be a proper arc which intersects  $\alpha_g$  transversely in one point and does not intersect any of the other curves. Further let  $c \subset S$  be the boundary of a (small) regular neighbourhood of



$\alpha_g \cup \beta_{g-1}$  in  $S$  and denote  $t_c$  the positive Dehn twist on  $c$ . Note that  $t_c$  acts as the identity on homology since  $c$  is nullhomologous in  $S$ , by construction (see Figure 2). For  $n \in \mathbb{N}$ , define the proper arc  $\gamma_n = t_c^n(\gamma)$ . Finally, let  $S_n$

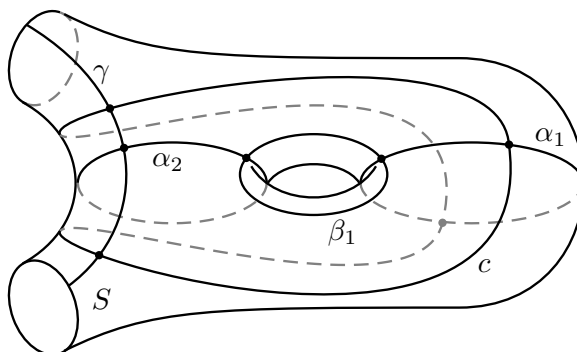

Figure 2: Position of the curves in the abstract surface  $S$  for  $g = 2$ .

be the surface obtained by plumbing a positive Hopf band  $H_{2g}$  along  $\gamma_n$  to  $S$  from below and denote  $\beta_{g,n}$  the core curve of  $H_{2g}$  in  $S_n$ . The monodromy  $\varphi_n : S_n \rightarrow S_n$  is given by

$$\varphi_n = (t_{\beta_{g,n}} \circ t_{\beta_{g-1}} \circ \cdots \circ t_{\beta_1}) \circ (t_{\alpha_g} \circ \cdots \circ t_{\alpha_1}).$$

In other words,  $\varphi_n$  is a composition of two positive multi-twists along systems of  $g$  disjoint curves. Each complementary region of the union  $\alpha_1 \cup \cdots \cup \alpha_g \cup \beta_1 \cup \cdots \cup \beta_{g-1} \cup \beta_{g,n}$  is either a boundary parallel annulus or a polygon which has at least three sides (corresponding to sub-arcs of the curves  $\alpha_i, \beta_i$ ). To see this, first cut the surface  $S_n$  along all the curves  $\alpha_i$  and  $\beta_i$  except  $\beta_{g,n}$ . The result is a pair of pants  $P$ , in which  $\beta_{g,n}$  appears as a finite union of disjoint properly embedded arcs, one of which connects two distinct components of  $\partial P$ . The final cut along  $\beta_{g,n}$  results in a boundary parallel annulus and some discs. Therefore, the curves fill up the surface  $S_n$  and they realise their geometric intersection number (apply the bigon criterion of [13]). Moreover their union is connected. This fits the setting of Thurston’s classical construction for products of multi-twists (compare Section 2.4 above; see also [42, Section 6]). To compute the geometric dilatation

$\lambda_n$  of  $\varphi_n$ , consider the  $g \times g$  geometric intersection matrix

$$N = \begin{bmatrix} 1 & & & & & & \\ 1 & 1 & & & & & \\ & & \ddots & \ddots & & & \\ & & & 1 & 1 & 4n & \\ & & & & 1 & 1 & \end{bmatrix}$$

whose entry  $N_{ij}$  is given by the number of intersection points (counted without sign) between  $\alpha_i$  and  $\beta_j$ . Note that  $\gamma \cap c$  and  $\alpha_{g-1} \cap c$  consist of two points each, which implies that  $\gamma_n$  (and therefore  $\beta_{g,n}$ ) intersects  $\alpha_{g-1}$  in  $4n$  points. Let  $\mu_n$  be the largest eigenvalue of the symmetric matrix  $NN^T$ , which is of the following form for  $g \geq 3$ .

$$NN^T = \begin{bmatrix} 1 & 1 & & & & & \\ 1 & 2 & & & & & \\ & & \ddots & 1 & & & \\ & & & 1 & 2 & 1 & \\ & & & & 1 & 2 + 16n^2 & 1 + 4n \\ & & & & & 1 + 4n & 2 \end{bmatrix}$$

By a classical theorem of Geršgorin [16], the eigenvalues of a matrix  $A$  are contained in the union of the discs in the complex plane with centers  $A_{ii}$  and radii  $\sum_{j \neq i} |A_{ij}|$  and if a disc is disjoint from the others, it must contain precisely one eigenvalue. For  $A = NN^T$ , we see that the Geršgorin disc of radius  $2 + 4n$  centered at the largest diagonal entry  $2 + 16n^2$  is disjoint from all others if  $n \neq 0$ . Therefore

$$16n^2 - 4n \leq \mu_n \leq 16n^2 + 4n + 4, \quad \forall n \neq 0,$$

hence the  $\mu_n$  are pairwise distinct and unbounded. By Thurston's construction, the map  $\varphi_n$  is pseudo-Anosov if and only if the following  $2 \times 2$  matrix representing  $\varphi_n$  is hyperbolic.

$$T_{\underline{\beta}} \cdot T_{\underline{\alpha}} = \begin{bmatrix} 1 & 0 \\ -\mu_n^{1/2} & 1 \end{bmatrix} \cdot \begin{bmatrix} 1 & \mu_n^{1/2} \\ 0 & 1 \end{bmatrix} = \begin{bmatrix} 1 & \mu_n^{1/2} \\ -\mu_n^{1/2} & 1 - \mu_n \end{bmatrix}$$

Its eigenvalues are the geometric stretching factors  $\lambda_n^{\pm 1}$  of  $\varphi_n$ . A quick computation yields

$$\lambda_n^{\pm 1} = \frac{1}{2}(2 - \mu_n \mp \sqrt{\mu_n^2 - 4\mu_n})$$

(we chose the signs such that  $|\lambda_n| \geq 1$  for  $n \neq 0$ ). In particular,  $|\lambda_n| \rightarrow \infty$  as  $n \rightarrow \infty$  and the  $\lambda_n$  are pairwise distinct. This implies that the knots  $K_n := \partial S_n$  are pairwise distinct and hyperbolic for  $n \neq 0$ . For  $n = 0$ , we have  $K_0 = T(2, 2g + 1)$ , since the corresponding fibre surface  $S_0$  is obtained by positive Hopf plumbing according to the tree  $\bullet \text{---} \bullet \text{---} \bullet \text{---} \bullet \text{---} \bullet$  on  $2g$  vertices. In particular,  $\varphi_0$  is a periodic mapping class and  $\lambda_0$  is a root of unity.

By construction,  $S_n$  is a plumbing of  $2g$  positive Hopf bands for all  $n$ . Since a plumbing of positive Hopf bands is strongly quasipositive [34] and fibred [40],  $K_n$  has the same properties, for all  $n \in \mathbb{N}$ .

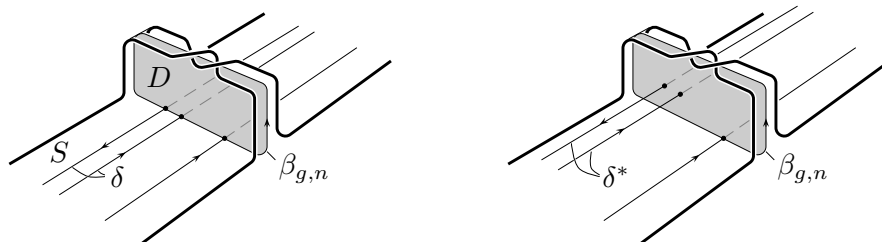

Figure 3: The linking number of  $\delta^*$  and  $\beta_{g,n}$  equals the algebraic intersection number of  $\delta$  and  $\beta_{g,n} \cap S$ .

It remains to show that the Seifert forms of the surfaces  $S_n$  agree, up to the obvious identification of  $H_1(S_n, \mathbb{Z}) = H_1(S, \mathbb{Z}) \oplus \langle \beta_{g,n} \rangle$  with  $H_1(S_m, \mathbb{Z}) = H_1(S, \mathbb{Z}) \oplus \langle \beta_{g,m} \rangle$ . The Seifert forms clearly agree on  $H_1(S, \mathbb{Z})$ , since the  $S_n$  are all given by plumbing on  $S$ . Now let  $\delta \subset S$  be a closed oriented curve and denote  $\delta^*$  a slight push-off along the (positive or negative) direction normal to  $S$ . We have to prove that the linking numbers of  $\beta_{g,n}$  and  $\beta_{g,m}$  with  $\delta^*$  agree. This follows from the fact that  $\beta_{g,n}$  and  $\beta_{g,m}$  bound discs whose interiors are disjoint from  $S$ , hence the linking numbers with  $\delta^*$  are given by the algebraic intersection numbers between  $\delta$  and  $\beta_{g,n}, \beta_{g,m}$ , respectively (compare Figure 3). The latter agree since the arcs  $\gamma_n$  and  $\gamma_m$  are homologous in  $S$  by construction.  $\square$

**Corollary 1.** *Let  $g \geq 2$ . There exist infinitely many hyperbolic strongly quasipositive fibred knots of genus  $g$ , having*

- 1) maximal signature,
- 2) periodic homological monodromy,
- 3) isomorphic Alexander modules.

*Proof.* In the proof of Theorem 1 we constructed an infinite family of strongly quasipositive fibred genus  $g$  knots  $K_n$ ,  $n \in \mathbb{N}$ , such that  $K_n$  is hyperbolic for  $n \neq 0$  and has the same Seifert form as  $K_0 = T(2, 2g + 1)$ . Since  $T(2, 2g + 1)$  has maximal signature, this immediately implies (1). A presentation matrix of the Alexander module of any given knot can be directly computed from its Seifert form [30, Theorem 8C3]. Thus the Alexander module is determined up to isomorphism by the Seifert form, which implies (3). The homological monodromy  $M$  of a fibre surface is related to its Seifert form  $A$  by the formula  $M = A^{-\top} A$  (compare [39, Lemma 8.3]). Hence  $K_n$  has the same homological monodromy as  $K_0$ , which is periodic. This establishes (2).  $\square$

**Proposition 1.** *Let  $K_n$ ,  $n \in \mathbb{N}$ , be the family of knots constructed in the proof of Theorem 1. The following holds for all  $i, j \in \mathbb{N}$ ,  $i \neq j$ .*

- 1)  $K_i$  and  $K_j$  are not ribbon concordant,
- 2)  $K_i$  and  $K_j$  are not homotopy ribbon concordant,
- 3) the closed monodromy of  $K_i \# (-K_j)$  does not extend over a handlebody,
- 4) the smooth four-ball genus of  $K_i \# (-K_j)$  is at most one.

**Remark.** Note that homotopy ribbon concordance is (a priori) not a symmetric relation. Here, we say that two knots are homotopy ribbon concordant if one of them is homotopy ribbon concordant to the other.

*Proof.* By [18, Lemma 3.4], two homotopy ribbon concordant transfinitely nilpotent knots whose Alexander polynomials have the same degree have to be equal (see [18] for the definition of transfinite nilpotency). This implies (2), since fibred knots are transfinitely nilpotent by [18, Corollary 5.4]. By a theorem of Casson and Gordon, (2)  $\Leftrightarrow$  (3) for fibred knots (see [11, Theorem 5.1]). The implication (2)  $\Rightarrow$  (1) holds for all knots. Assertion (4) essentially follows from the fact that the surface  $S_i \# (-S_j)$  is given by plumbing two Hopf bands to the surface  $S \# (-S)$ , which is ribbon. More precisely, we can find a zero-framed unlink with unknotted components  $L_1, \dots, L_{2g} \subset S_i \# (-S_j)$  which are realised as the embedded connected sum of the copies of the curves  $\alpha_k, \beta_k$  in  $S$  and  $-S$ , respectively. Cut  $S_i \# (-S_j)$  along  $L_k$  and glue two ribbon discs back in, for each  $k$ . Push the interior of the resulting surface slightly into the four-ball to obtain a ribbon surface of genus one.  $\square$

#### 4. Further properties of the knots $K_n$

The subsequent statements refer to the family of knots  $K_n$  of a fixed genus  $g \geq 2$  constructed in the proof of Theorem 1.

- 1) Since the signature of a knot is a lower bound for the topological four-ball genus, we also have that  $g_4^{top}(K_n) = g_4(K_n) = g(K_n)$ . In particular, the  $K_n$  are not slice (see [22] and [36]).
- 2) The equality of the Seifert forms also implies that the Levine-Tristram signature functions of the knots  $K_n$  agree.
- 3) The Alexander polynomial of  $K_n$  is equal to the Alexander polynomial of  $T(2, 2g + 1)$  and the knots  $K_n \# (-K_m)$  satisfy the Fox-Milnor condition.
- 4) By work of Hedden [19], the concordance invariant  $\tau$  is maximal for the knots  $K_n$ , that is,  $\tau(K_n) = g(K_n) = g$ . Moreover, the open book associated to  $K_n$  supports the tight contact structure of  $S^3$ , so the geometric monodromy of  $K_n$  is right-veering [21].
- 5) The knots  $K_n$  are all prime since their geometric monodromies are irreducible (they are pseudo-Anosov for  $n \neq 0$ ).
- 6) For  $n \neq 0$ ,  $K_n$  cannot be represented by a positive braid. In fact, positive braids of maximal signature have been classified by Baader [2]. They all have periodic (geometric) monodromy. All but finitely many of the  $K_n$  (probably all but  $K_0$ ) cannot be represented by a positive knot diagram. This follows from the fact that the number of positive knots of a fixed genus and fixed signature function is finite; compare [3, Proof of Theorem 1].
- 7) Similarly, all but finitely many of the  $K_n$  are non-alternating, since the number of alternating links of a given Alexander polynomial is finite by work of Stoimenow [41, Corollary 3.5].
- 8) Except for a finite number of indices, the fibre surfaces of the  $K_n$  cannot be Hopf-plumbed baskets (given by Hopf plumbing along arcs on a fixed disc [37]). In fact, the number of Hopf-plumbed baskets of a given genus is finite. This suggests that baskets should be thought of as rare exceptions among quasipositive fibre surfaces, at least from the point of view of general Hopf plumbing. See also [5].

- 9) The knots  $K_n$  can be obtained from  $K_0$  by Dehn surgery on a fixed link. Recall the nullhomologous curve  $c \subset S \subset S_0$  from the proof of Theorem 1. Consider two curves  $a, b \subset S^3 \setminus S_0$  which are obtained by pushing  $c$  off  $S$  in the negative normal direction, such that  $a$  intersects the plumbing disc bounded by  $\beta_{g,0}$  in two points near  $\gamma \cap c$ , and  $b$  is pushed further out such that it does not link  $\beta_{g,0}$ . The curves  $a, b$  cobound an annulus which intersects the last plumbed Hopf band  $H_{2g}$  in two parallel arcs and has no other intersection with  $S_0$  (compare Figure 4). Then  $K_n$  is obtained from  $K_0$  by  $-\frac{1}{n}$  Dehn surgery on  $a$ , followed by  $+\frac{1}{n}$  Dehn surgery on  $b$ . The resulting ambient manifold is  $S^3$  again, because  $a$  and  $b$  are parallel and the surgery coefficients cancel (compare [28, Theorem 2.1]). As a consequence, the volume of  $K_n$  is bounded.

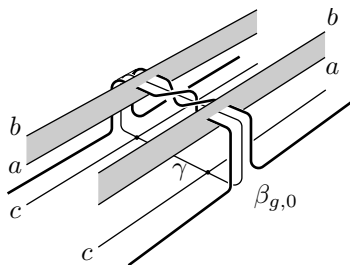

Figure 4: The surgery link  $a \cup b \subset S^3 \setminus S_0$  bounds an annulus (grey-shaded).

**Acknowledgements.** I would like to thank Michel Boileau for inspiring discussions during my stay at the University of Aix-Marseille, where this article was written. Michel Boileau, Ken Baker, Marco Golla and one of the anonymous referees have independently pointed out the question whether or not the knots  $K_n$  are L-space knots, respectively have L-space branched covers. I would like to thank the referees for their remarks and suggestions which helped to improve the text.

## References

- [1] S. Baader, *Fibered knot with periodic homological monodromy*, Math-Overflow post, URL (version: 2013-09-30): <http://mathoverflow.net/q/143579>.
- [2] S. Baader, *Positive braids of maximal signature*, Enseign. Math. **59** (2013), no. 3–4, 351–358.

- [3] S. Baader, P. Dehornoy, and L. Liechti, *Signature and concordance of positive knots*, Bull. London Math. Soc. **50** (2018), no. 1, 166–173.
- [4] K. Baker, *A note on the concordance of fibered knots*, J. Topol. **9** (2016), no. 1, 1–4.
- [5] I. Banfield, *Almost all strongly quasipositive braid closures are fibered*, arXiv:1610.09664, (2016).
- [6] M. Boileau, S. Boyer, and C. Gordon, *Branched covers of quasipositive links and  $L$ -spaces*, J. Topol. **12** (2019), no. 2, 536–576.
- [7] S. Boyer, C. Gordon, and L. Watson, *On  $L$ -spaces and left-orderable fundamental groups*, Math. Ann. **356** (2013), no. 4, 1213–1245.
- [8] M. Boileau and S. Orevkov, *Quasi-positivité d’une courbe analytique dans une boule pseudo-convexe*, C. R. Acad. Sci. Paris Sér. I Math. **332** (2001), no. 9, 825–830.
- [9] F. Bonahon, *Ribbon fibred knots, cobordism of surface diffeomorphisms, and pseudo-Anosov diffeomorphisms*, Math. Proc. Camb. Phil. Soc. **94** (1983), no. 2, 235–251.
- [10] F. Bonahon, *Cobordism of automorphisms of surfaces*, Ann. Sci. École Norm. Sup. (4) **16** (1983), no. 2, 237–270.
- [11] A. Casson and C. McA. Gordon, *A loop theorem for duality spaces and fibred ribbon knots*, Inventiones Math. **74** (1982), 119–137.
- [12] A. Edmonds and C. Livingston, *Group actions on fibered three-manifolds*, Comment. Math. Helv. **58** (1983), no. 4, 529–542.
- [13] B. Farb and D. Margalit, *A Primer on Mapping Class Groups*, Princeton Mathematical Series, 49, Princeton University Press, Princeton, NJ (2012), ISBN 978-0-691-14794-9.
- [14] A. Fathi, F. Laudenbach, and V. Poenaru (eds.), *Travaux de Thurston sur les Surfaces*, Astérisque **66-67**. Séminaire Orsay. Société Mathématique de France, (1979).
- [15] R. H. Fox, *Some problems in knot theory*, Topology of 3-Manifolds and Related Topics (Proc. Univ. Georgia Institute, 1961), Prentice-Hall, Englewood Cliffs, N.J. (1962), 168–176.
- [16] S. Geršgorin, *Über die Abgrenzung der Eigenwerte einer Matrix*, Bulletin de l’Académie des Sciences de l’URSS (1931), no. 6, 749–754.

- [17] P. Ghiggini, *Knot Floer homology detects genus-one fibred knots*, Amer. J. Math. **130** (2008), no. 5, 1151–1169.
- [18] C. McA. Gordon, *Ribbon concordance of knots in the 3-sphere*, Math. Ann. **257** (1981), no. 2, 157–170.
- [19] M. Hedden, *Notions of positivity and the Ozsváth-Szabó concordance invariant*, J. Knot Theory Ramif. **19** (2010), no. 5, 617–629.
- [20] M. Hedden, *Some remarks on cabling, contact structures, and complex curves*, in: Proceedings of the 14th Gökova geometry-topology conference, Gökova, Turkey, May 28–June 2, 2007. Cambridge, MA: International Press, pp. 49–59.
- [21] K. Honda, W. H. Kazez, and G. Matić, *Right-veering diffeomorphisms of compact surfaces with boundary*, Invent. Math. **169** (2007), no. 2, 427–449.
- [22] L. H. Kauffman and L. R. Taylor, *Signature of links*, Trans. Amer. Math. Soc. **216** (1976), 351–365.
- [23] J. Milnor, *Singular Points on Complex Hypersurfaces*, Ann. of Math. Stud. **61**, Princeton University Press, Princeton, (1968).
- [24] F. Misev and G. Spano, *Tight fibred knots without L-space surgeries*, Glasgow Mathematical Journal (2020), 1–9.
- [25] K. Murasugi, *On a certain numerical invariant of link types*, Trans Amer. Math. Soc. **117** (1965), 387–422.
- [26] Yi Ni, *Knot Floer homology detects fibred knots*, Invent. Math. **170** (2007), no. 3, 577–608.
- [27] Yi Ni, *Erratum: Knot Floer homology detects fibred knots*, Invent. Math. **177** (2009), no. 1, 235–238.
- [28] J. Osoinach, *Manifolds obtained by surgery on an infinite number of knots in  $S^3$* , Topology **45** (2006), no. 4, 725–733.
- [29] P. Ozsváth and Z. Szabó, *On knot Floer homology and lens space surgeries*, Topology **44** (2005), 1281–1300.
- [30] D. Rolfsen, *Knots and Links*, corrected reprint of the 1976 original, Mathematics Lecture Series **7**, Publish or Perish, Inc., Houston, TX, (1990), xiv+439 pp. ISBN 0-914098-16-0.



- [31] L. Rudolph, *Constructions of quasipositive knots and links. I*, Nœuds, Tresses, et Singularités (ed. C. Weber), L'Enseign. Math. **31** (Kundig, Geneva, 1983), 233–246.
- [32] L. Rudolph, *Algebraic functions and closed braids*, Topology **22** (1983), no. 2, 191–202.
- [33] L. Rudolph, *A characterization of quasipositive Seifert surfaces (Constructions of quasipositive knots and links, III)*, Topology **31** (1992), no. 2, 231–237.
- [34] L. Rudolph, *Quasipositive plumbing (Constructions of quasipositive knots and links. V)*, Proc. Amer. Math. Soc. **126** (1998), no. 1, 257–267.
- [35] L. Rudolph, *Positive links are strongly quasipositive*, Geometry & Topology Monographs **2**, Proceedings of the Kirbyfest (1999), 555–562.
- [36] L. Rudolph, *Quasipositivity as an obstruction to sliceness*, Bull. Amer. Math. Soc., **29** (1993), no. 1, 51–59.
- [37] L. Rudolph, *Hopf plumbing, arborescent Seifert surfaces, baskets, espaliers, and homogeneous braids*, Topology Appl. **116**, no. 3 (2001), 255–277.
- [38] L. Rudolph, *Knot theory of complex plane curves*, in: Handbook of Knot Theory (W. Menasco and M. Thistlethwaite (eds.)), Chapter 8, 349–427, Elsevier, (2005). ISBN 0-444-51452-x.
- [39] N. Saveliev, *Lectures on the Topology of 3-Manifolds: An Introduction to the Casson Invariant*, De Gruyter, (2012).
- [40] J. Stallings, *Constructions of fibred knots and links*, Algebraic and geometric topology, Proc. Sympos. Pure Math. **32** (1978), 55–60, Amer. Math. Soc., Providence, RI.
- [41] A. Stoimenow, *Knots of genus one*, Proc. Amer. Math. Soc. **129** (2001), no. 7, 2141–2156.
- [42] W. P. Thurston, *On the geometry and dynamics of diffeomorphisms of surfaces*, Bull. Amer. Math. Soc. **19** (1988), no. 2.

INSTITUT DE MATHÉMATIQUES (I2M), UNIVERSITÉ AIX-MARSEILLE  
39 RUE F. JOLIOT CURIE, 13453 MARSEILLE, FRANCE

*E-mail address:* `filip.misev@univ-amu.fr`

RECEIVED DECEMBER 7, 2017

ACCEPTED JUNE 4, 2018