

Finite group actions on Lagrangian Floer theory

CHEOL-HYUN CHO AND HANSOL HONG

We construct finite group actions on Lagrangian Floer theory when symplectic manifolds have finite group actions and Lagrangian submanifolds have induced group actions. We first define finite group actions on Novikov-Morse theory. We introduce the notion of a *spin profile* as an obstruction class of extending the group action on Lagrangian submanifold to the one on its spin structure, which is a group cohomology class in $H^2(G; \mathbb{Z}/2)$. For a class of Lagrangian submanifolds which have the same spin profiles, we define a finite group action on their Fukaya category. In consequence, we obtain the s -equivariant Fukaya category as well as the s -orbifolded Fukaya category for each group cohomology class s . We also develop a version with G -equivariant bundles on Lagrangian submanifolds, and explain how character group of G acts on the theory. As an application, we define an orbifolded Fukaya-Seidel category of a G -invariant Lefschetz fibration, and also discuss homological mirror symmetry conjectures with group actions.

1	Introduction	308
2	G-Novikov theory in the easiest case	316
3	General G-Novikov theory	323
4	Floer-Novikov theory and orientation spaces	335
5	Spin profiles	345
6	Equivariant Fukaya categories for exact symplectic manifolds	358
7	Energy zero subgroups for non-exact cases	365

8	Group actions on Floer-Novikov complexes	371
9	Equivariant transversality	379
10	Group actions on A_∞-algebra of a Lagrangian submanifold	386
11	G-equivariant A_∞-bimodule $CF_{R,l_0}^*(L_0, L_1)$	392
12	Equivariant flat vector bundles on G-invariant Lagrangians	396
13	Fukaya-Seidel category of G-Lefschetz fibrations	401
14	Some examples of group actions and mirror symmetry	405
15	$\mathbb{C}P^2$ with a $\mathbb{Z}/3$-action	411
	References	416

1. Introduction

A group action is one of the most important tool in the study of mathematical objects. Finite group actions in symplectic geometry appear in various contexts, such as mirror symmetry, singularity theory, etc. In this paper, we will construct finite group actions on Lagrangian Floer theory. Lagrangian Floer homology (developed by Floer[20], Oh[33], Fukaya-Oh-Ohta-Ono [25]) has been a powerful tool, which revolutionized the study of symplectic topology. Furthermore, its categorical versions, Fukaya category (Fukaya [21]) and Fukaya-Seidel category (Seidel [37], [38]), are the main players of homological mirror symmetry as envisioned by Kontsevich [29].

When a symplectic manifold as well as a Lagrangian submanifold admits a finite group action, it is indeed quite natural to expect that such an action exists on Lagrangian Floer theory. But there are several technical difficulties to define such an action as we will explain below. In the case of $\mathbb{Z}/2$ -actions on exact symplectic manifolds, Seidel has defined $\mathbb{Z}/2$ -equivariant Fukaya categories [37]. Another known case is when a group acts freely on the set of connected components of a given exact Lagrangian submanifold in an exact symplectic manifold. In such a case, it is relatively easy to define a group action, since one can use pull-back data (such as spin structure, perturbation

data, etc) to make Floer theory compatible with the given group action. Such construction was proposed by Seidel [38] in his study of mirror symmetry of quartic surfaces in an exact setting.

Let us now describe our main results. We will first explain the exact case, and later the case of general closed symplectic manifolds. For an exact symplectic manifold (M, ω) , consider a G -invariant exact Lagrangian submanifold L , which means that a G -action preserves the Lagrangian submanifold. Suppose that L is spin and that its spin structure is G -invariant. We show that the G -action on L gives rise to a group cohomology class in $H^2(G, \mathbb{Z}/2)$, “the spin profile of L ”, which is the obstruction to extending the group action to the spin bundle of L . The main observation is that if two Lagrangian submanifolds have the same spin profile, then it is possible to define a group action on the Lagrangian Floer cohomology of the pair in the exact case.

Thus for each cohomology class $s \in H^2(G, \mathbb{Z}/2)$, an s -equivariant brane is defined as a G -invariant exact Lagrangian submanifold whose associated spin profile is s , with a G -invariant grading.

Theorem 1.1 (see Theorem 6.3). *Let (M, ω) be an exact symplectic manifold. For $s \in H^2(G, \mathbb{Z}/2)$, an s -equivariant Fukaya category can be defined as follows. An object of s -equivariant Fukaya category is given by an s -equivariant brane. Morphism between two s -equivariant branes L_0^\sharp, L_1^\sharp are given by $CF^*(L_0^\sharp, L_1^\sharp)$, which has a G -action. There are A_∞ -operations*

$$m_k : CF^*(L_0^\sharp, L_1^\sharp) \times \cdots \times CF^*(L_{k-1}^\sharp, L_k^\sharp) \rightarrow CF^*(L_0^\sharp, L_k^\sharp), \quad k = 1, 2, \dots$$

which are compatible with the G -action. i.e. for $k = 1, 2, \dots$

$$(1.1) \quad m_k(gx_1, \dots, gx_k) = gm_k(x_1, \dots, x_k).$$

To be more precise, we should equip each s -equivariant brane with a G -equivariant flat complex vector bundle as in Section 12. The s -orbifolded Fukaya category is defined to have the same set of objects as the s -equivariant Fukaya category, but we take G -invariant parts of morphisms of the s -equivariant category. Then, the s -orbifolded Fukaya category naturally inherits an A_∞ -structure from the s -equivariant category from (1.1).

As an application, we define both equivariant and orbifolded Fukaya-Seidel categories of a G -invariant Lefschetz fibration. Namely, for each $s \in H^2(G, \mathbb{Z}/2)$, we define s -equivariant Fukaya-Seidel category of $\pi : M \rightarrow \mathbb{C}$ (See Definitions 13.2, 13.3). By taking G -invariant parts on morphisms, and

the induced A_∞ -structure, we obtain the s -orbifolded Fukaya-Seidel category of (π, G) .

Let us turn our discussion to the case of a general closed symplectic manifold (which is not exact) with an effective action of a finite group G . Consider a Lagrangian submanifold L_i ($i = 0, 1$), which has an induced G -action. Suppose that L_i has a G -invariant spin structure, with a spin profile $s_i \in H^2(G; \mathbb{Z}/2)$ for $i = 0, 1$. Fix a base path $l_0 : [0, 1] \rightarrow M$ such that $l_0(i) \in L_i$ for $i = 0, 1$. Let G_α be the energy zero subgroup G_α of l_0 as in Definition 7.2.

Theorem 1.2 (see Definition 8.8, Propositions 8.10, 11.5). *If $s_0 = s_1$, then the Lagrangian Floer filtered cochain complex of L_0, L_1 admits a G_α -action. More generally, filtered A_∞ -bimodule of the pair (L_0, L_1) admits a natural G_α -action.*

Proposition 1.3 (see Section 11). *Suppose that L_0 is connected and let $L_1 = \phi_H^1(L_0)$. Then $G_\alpha = G$, and we have a G -equivariant filtered A_∞ -bimodule quasi-isomorphism*

$$\Omega(L) \widehat{\otimes} \Lambda_{nov} \rightarrow CF_{R, l_0}^*(L, L_1) \otimes_{\Lambda(L, L_1; l_0)} \Lambda_{nov}.$$

The method developed in this paper, together with the work of Fukaya in [23] should define equivariant Fukaya categories in the general case.

More detailed introduction and description are now in order.

1.1. Spin profiles

In this paper, we introduce the notion of a *spin profile* of a Lagrangian submanifold with a G -action. Such a notion is deeply related to the orientation of the moduli space of J -holomorphic discs and the G -action on it. Recall that if a Lagrangian submanifold is spin, a choice of spin structure determines canonical orientations of the moduli spaces of J -holomorphic discs (see [25]). Hence, we need to analyze the relation between the group action on L and that of its spin structure.

We assume that the related spin structure is G -invariant, which means that for a principal spin bundle $P \rightarrow L$, the pull-back bundle g^*P via the action of $g \in G$ is isomorphic to the original bundle P . In fact, the precise isomorphism between g^*P and P (as in G -equivariant sheaves), which can be considered as a lift of the g -action to the one on spin bundle, will be necessary to determine the sign of the g -action on the Floer complex. In

general, these isomorphisms are not necessarily compatible with each other, and the G -action on L does *not* lift to the one on the spin bundle. Hence, one can not expect that any orientation preserving action of a symplectic manifold gives rise to an action on its Fukaya category.

A *spin profile* is defined as the group cohomology class in $H^2(G, \mathbb{Z}/2)$ which measures the obstruction to extending the action of G on a manifold to the one on its spin structure. We show that if spin profiles of two Lagrangian submanifolds coincide, then we are able to define a group action on Lagrangian Floer theory of a pair (we need to develop G -Novikov theory additionally for non-exact symplectic manifolds). The main point is that the exact signs from failures of group actions on spin bundles cancel out for Lagrangians with the same spin profiles. This means that the equivariant Fukaya category is defined for each choice of spin profiles in $H^2(G, \mathbb{Z}/2)$. Construction of the $\mathbb{Z}/2$ -equivariant Fukaya category by Seidel [37], in fact, corresponds to the non-trivial class in $H^2(\mathbb{Z}/2, \mathbb{Z}/2)$. We explain several properties of spin profiles, and also the change of spin profiles under the change of spin structures.

1.2. Equivariant Fukaya categories for exact cases and G -Lefschetz fibrations

Let (M, ω) be an exact symplectic manifold with an effective action of a finite group G . We fix a class $s \in H^2(G, \mathbb{Z}/2)$, and consider s -equivariant branes as explained above. It may happen that some of g -action send L to $g(L)$ which is disjoint from L , in which case we can take $\sqcup_{g \in G, g(L) \neq L} g(L)$ to be the new G -invariant Lagrangian submanifold. We do not assume that L is connected in the exact case.

In general, the equivariant Fukaya category of M should also have G -equivariant Lagrangian immersions to M . In the sequel of this paper [14], we will investigate extensively such G -equivariant Lagrangian immersions, and explore the relationship of $G \times G$ -equivariant immersions into $M \times M$ with Chen-Ruan orbifold cohomology of $[M/G]$. In fact, one should consider a more general notion of orbifold embeddings [3], but they were shown to be equivalent to G -equivariant immersions for global quotients in [16], and hence it is enough to study the latter.

There is another technical issue, which are equivariant transversalities of the related moduli spaces of holomorphic discs. Namely, we would like to choose perturbation data equivariantly, so that we have strict G -equivariant A_∞ -operations. In the exact case, we follow Seidel [38] to achieve it with aid of an algebraic machinery. In the general case later, Kuranishi structure (as

in [24], [25], [23]) will be used, which is in fact a device to achieve this kind of equivariant transversality.

We construct a version of Donaldson-Fukaya categories (C in Definition 6.11), and produce a G -action on it from the weak G -action on the related Floer complex (see [13] for the weak G -actions on Morse complexes). Then, the homological perturbation type lemma of Seidel (Lemma 4.3 of [38]) enables us to define the s -equivariant Fukaya category for an exact symplectic manifold. By taking G -invariant parts on morphism spaces, the s -orbifolded Fukaya category of $[M/G]$ is obtained. This should be regarded as a first approximation of orbifold theory, as we should also add bulk deformation by twisted sectors as in [18].

As an application, we define *the directed equivariant (and the orbifolded) Fukaya-Seidel category* of a G -invariant Lefschetz fibration $\pi : M \rightarrow \mathbb{C}$, where M is equipped with a G -action, and π is G -invariant. In mirror symmetry, orbifolds and orbifolded Landau-Ginzburg models appear naturally, and have been actively investigated. Our work provides the necessary framework to state homological mirror symmetry in these cases by defining appropriate orbifold Fukaya categories. We only deal with G -invariant Lefschetz fibrations in this paper and leave the case of an orbifolded LG -model which is not Lefschetz fibration and of a G -equivariant LG -model to the future investigation.

1.3. G -Novikov theory

For a closed symplectic manifold which is not exact, the Lagrangian Floer cohomology is the Morse-Novikov homology on path spaces between two Lagrangian submanifolds. Hence, we need to develop G -Novikov theory.

We first recall G -Morse theory from our previous work [13]. Given a Morse-Smale function $f : M \rightarrow \mathbb{R}$ on a compact manifold M , one can define the Morse-Smale-Witten complex (Morse complex for short) by counting gradient flow lines between critical points of f . If f is G -invariant, we studied how to define a finite group action on the Morse complex, whose homology of the G -invariant part is isomorphic to the singular homology of the quotient orbifold. One of the main observation of [13] is that one should consider not only the action on critical points, but also on the orientation spaces (defined from their unstable manifolds).

Now, Morse-Novikov theory (Novikov theory for short) generalizes Morse theory to the case of a general closed Morse one form η , instead of df . Novikov theory is a kind of Morse theory associated to a Morse function on a certain Novikov covering (so that the pull-back of the given closed one

form becomes exact), together with the action of the group ring of its deck transformation group.

In this paper, we define finite group actions on Novikov theory. The main difficulty is that the base point chosen for Novikov theory is *not* preserved by the group action. We resolve this issue by introducing the subgroup G_η of energy zero elements of G , where $g \in G$ is said to be energy zero if there is an energy zero path (with respect to the action functional) from the base point to its g -action image. And we will construct an action of energy zero subgroup on the Novikov complex using this energy zero path. Together with an appropriate orbifold Novikov ring coefficient, taking G_η -invariant part defines G -Novikov theory

1.4. Group actions in general Lagrangian Floer theory

By using spin profiles and G -Novikov theory, we can define group actions on Lagrangian Floer cohomology groups for non-exact cases as follows. Let (M, ω) be a closed symplectic manifold with an effective G -action. Fix $s \in H^2(G, \mathbb{Z}/2)$ and consider a Lagrangian submanifold L_i (for $i = 0, 1$) whose spin profile is s . For a base path l_0 between L_0 and L_1 , take an energy zero surface w_g connecting l_0 and $g(l_0)$ for g in the energy zero subgroup G_α (Definition 7.2) as an analogue of G -Novikov theory. We assume that $G = G_\alpha$ for simplicity. For each generator of the Floer complex of a pair (L_0, L_1) , one can consider its orientation space, which is the determinant bundle of the associated Cauchy-Riemann operator. This construction already appeared in [25, 3.7.5], and Seidel also used orientation spaces in exact cases. Then, the actual group action is defined to be an action on orientation spaces, where the action image is obtained by gluing the determinant bundles of w_g to the naive g -action image of a generator of the Floer complex (see Definition 8.8). Here, the Lagrangian bundle data along the boundary ∂w_g will be given a specific spin structure. A cocycle condition of the group action may not be satisfied, but its obstruction can be precisely measured from Proposition 7.4 to be

$$(-1)^{\text{spf}_{L_0}(g,h) + \text{spf}_{L_1}(g,h)}.$$

This guarantees that if the spin profiles of L_0 and L_1 coincide, cocycle conditions of the group action are satisfied.

In this way, we get a well-defined action of G on the Floer cochain complex $CF_{R,l_0}(L_0, L_1)$ between L_0 and L_1 . With equivariant Kuranishi perturbations, we show that the Floer differential as well as the A_∞ -bimodule structure on $CF_{R,l_0}(L_0, L_1)$ is compatible with the G -action. Therefore, the

bimodule structure descends to the G -invariant part of $CF_{R,l_0}(L_0, L_1)$, which should be interpreted as a morphism space between $[L_0/G]$ and $[L_1/G]$ in the Fukaya category of the orbifold $[M/G]$.

Invariance of the Floer cohomologies under G -invariant Hamiltonians can be proven as well. That is, if L_1 is the Hamiltonian deformation of L_0 by a G -invariant Hamiltonian function on M , then the assumption $G_\alpha = G$ always holds and moreover, $HF(L_0, L_0)$ and $HF(L_0, L_1)$ are G -equivariantly isomorphic as $HF(L_0, L_0)$ -modules.

1.5. Mirror symmetry

For the purpose of mirror symmetry, we need to consider complex flat line bundles on Lagrangian submanifolds. With G -action, G -equivariant structures of such bundles should be also taken into account. The constructions in this paper can be adapted to the cases with G -equivariant line bundles by following the standard constructions. Such a G -equivariant bundle may be considered as an orbi-bundle on the orbi-Lagrangian $[L/G]$. Hence an object of an orbifolded category $\mathcal{Fuk}_G(X)$ is given by a G -invariant Lagrangian (or a G -equivariant immersion) equipped with a G -equivariant line bundle on it. Here morphisms of $\mathcal{Fuk}_G^s(X)$ are obtained by taking the G -invariant part of morphisms in the G -equivariant category.

Recall that B -branes of mirror symmetry are given by derived categories of coherent sheaves. When there is a group action, it is natural to work with G -equivariant sheaves.

Remark 1.4. The standard naming convention for equivariant sheaves are unfortunately different from ours. Namely, what we call an orbifolded category (taking G -invariant parts on morphisms of an equivariant category), is called an equivariant category for the case of sheaves.

We will see later that if X is given by a Lagrangian torus fiber bundle equipped with an action of G compatible with bundle structure, then its dual torus bundle Y naturally admits a G -action. In general, if Y is given as a SYZ (Strominger-Yau-Zaslow) mirror of X , we conjecture that the (derived) orbifold category $D\mathcal{Fuk}_G(X)$ is equivalent the derived category of G -equivariant sheaves on Y . When the mirror of X is a Landau-Ginzburg model $W : Y \rightarrow \mathbb{C}$, it turns out that W is invariant under the G -action on Y . We conjecture that homological mirror symmetry is the equivalence between the G -equivariant matrix factorization category of W and orbifolded Fukaya

category $\mathcal{Fuk}_G(X)$. (see Section 14 for the precise statements including spin profile data)

Character group of G acts on both sides of mirror by twisting the equivariant structures on bundles. Namely, given an orbifold bundle (or G -equivariant bundle) for $\mathcal{Fuk}_G(X)$, one can change G -equivariant structure by multiplying a character. We expect that these actions are compatible with homological mirror symmetry. We will look into toric cases, and present more conjectures and examples.

Let us also mention that in a forthcoming work with Siu-Cheong Lau, we will analyze mirror symmetry phenomena for G -equivariant immersions into finite group quotients, and construct a *localized homological mirror functor* for immersed Lagrangian submanifolds.

Notations and conventions

We will assume throughout the paper that G is a finite group. And G -action are always assumed to be effective, proper, and orientation preserving, unless stated otherwise. A submanifold $L \subset M$ preserved by the G -action of M is called G -invariant. Here, the action of $g \in G$ sends L to L , but it may not fix L pointwisely. In fact, if L is a Lagrangian submanifold of M and g fixes every point of L , then it is easy to see that g fixes a neighborhood of L in M . Since the action on M is assumed to be effective, such g should be the identity element of G .

Let R be a field containing Θ , and we will use $R = \mathbb{R}$ or \mathbb{C} for Floer theory. We use the following R -normalization convention due to Seidel [37, Section (12e)]. This is because, roughly speaking, we are only interested in the signs, rather than magnitudes in orientations spaces. For any 1-dimensional real vector space Θ , we denote by $|\Theta|_R$ the 1-dimensional R -vector space generated by the two orientations of Θ , with the relation that the sum of two generators is zero. An R -linear isomorphism $\phi : \Theta_1 \rightarrow \Theta_2$ induces a R -linear isomorphism $|\phi|_R : |\Theta_1|_R \rightarrow |\Theta_2|_R$, called the R -normalization of ϕ . Normalization will be also used in families, turning real line bundles into local coefficient systems with fiber R . It can be thought of as passing to the associated bundle via the homomorphism given by

$$\mathbb{R}^\times \rightarrow \{\pm 1\} \subset R^\times, \quad t \rightarrow t/|t|.$$

To simplify notations, we denote also by $g \in G$ the diffeomorphism of M induced by the action of g (sometimes written as A_g). For $\phi : M \rightarrow N$, we

denote by ϕ_{\sharp} the induced map on the fundamental group $\phi_{\sharp} : \pi_1(M, x_0) \rightarrow \pi_1(N, \phi(x_0))$. We denote by $\gamma_1 \star \gamma_2$, the concatenation of two paths γ_1 and γ_2 .

2. G-Novikov theory in the easiest case

In this section, we review Novikov theory by considering G -Novikov theory under the assumption 2.1. In this case, G -Novikov theory is given by an equivariant version of the standard one. Also, we will review G -Morse theory from our previous work [13], which is needed for the proper definition of the group action on a Novikov complex.

Assumption 2.1. There exists a point $x_0 \in M$ such that $g \cdot x_0 = x_0$ for all $g \in G$.

This assumption enables us to have a natural G -action on the fundamental group $\pi_1(M, x_0)$. We will fix a base point to be x_0 , and simply write $\pi_1(M)$ for $\pi_1(M, x_0)$ in this section. Note that the G -action on $\pi_1(M)$ is compatible with the group operations of $\pi_1(M)$. i.e. the G -action gives a group homomorphism $G \rightarrow \text{Aut}(\pi_1(M))$.

2.1. Novikov coverings

For a closed 1-form η on M , we call η a *Morse 1-form* if the graph of η in T^*M is transversal to the zero section. Assume further that η is G -invariant. η gives rise to a homomorphism $I_{\eta} : \pi_1(M) \rightarrow \mathbb{R}$,

$$(2.1) \quad I_{\eta}(\alpha) = \int_{S^1} \alpha^* \eta,$$

for $\alpha \in \pi_1(M)$. Note that I_{η} is G -invariant as well, i.e. $I_{\eta}(g \cdot \alpha) = I_{\eta}(\alpha)$.

Let $\pi : \widetilde{M} \rightarrow M$ be the covering space associated to the kernel of I_{η} , denoted by $\text{Ker}I_{\eta}$. (i.e. for the universal covering \widetilde{M}_{uni} of M , we have $\widetilde{M} = \widetilde{M}_{uni}/\text{Ker}I_{\eta}$). We fix a base point \widetilde{x}_0 in \widetilde{M} such that $\pi(\widetilde{x}_0) = x_0$.

Lemma 2.2. *There is an induced G -action on \widetilde{M} and $\pi : \widetilde{M} \rightarrow M$ is G -equivariant.*

Proof. Since I_{η} is G -invariant, $\text{Ker}I_{\eta}$ is preserved by $g_{\sharp} : \pi_1(M) \rightarrow \pi_1(M)$. Hence for any $g \in G$,

$$g_{\sharp}(\pi_{\sharp}\pi_1(\widetilde{M})) = g_{\sharp}(\text{Ker}I_{\eta}) = \text{Ker}I_{\eta}$$

Thus, the composition map $g \circ \pi : \widetilde{M} \rightarrow M$ has a unique lift $\widetilde{g} : \widetilde{M} \rightarrow \widetilde{M}$ such that $\widetilde{g}(\widetilde{x}_0) = \widetilde{x}_0$. The lemma, then, follows from the standard covering theory. \square

The deck transformation group Γ of the covering $\widetilde{M} \rightarrow M$ is given by $\pi_1(M)/\text{Ker}I_\eta$, and the Novikov ring $\Lambda_{[\eta]}$ is a completion of the group algebra of Γ :

$$(2.2) \quad \Lambda_{[\eta]} = \left\{ \sum a_i h_i \mid a_i \in R, h_i \in \Gamma, |\{i : a_i \neq 0, I_\eta(h_i) < c\}| < \infty \forall c \in \mathbb{R} \right\},$$

where R is a commutative ring with unity.

Lemma 2.3. *The induced G -action on $\Gamma = \pi_1(M)/\text{Ker}I_\eta$ is trivial.*

Proof. Since I_η is G -invariant, G acts on $\Gamma = \pi_1(M)/\text{Ker}I_\eta$. However, for $\alpha \in \pi_1(M)$,

$$\begin{aligned} I_\eta((g \cdot \alpha) \star \alpha_-) &= I_\eta(g \cdot \alpha) - I_\eta(\alpha) \\ &= I_\eta(\alpha) - I_\eta(\alpha) = 0, \end{aligned}$$

where $\alpha_-(t) = \alpha(1 - t)$. \square

We have two group actions on \widetilde{M} , which are the action of deck transformation group Γ and the induced action of G . The following lemma will play an important role later.

Lemma 2.4. *The Γ -action and the G -action on \widetilde{M} commute with each other. Namely for each $g \in G$, and $h \in \Gamma$, we have*

$$\widetilde{g} \circ h = h \circ \widetilde{g}.$$

Proof. We first work over the universal cover \widetilde{M}_{univ} . Note that we can lift the G -action on M to the G -action on the universal cover \widetilde{M}_{univ} similar as in Lemma 2.2. For a deck transformation h of \widetilde{M}_{univ} , we denote the corresponding loop in $\pi_1(M)$ by α_h .

The action of g takes the loop α_h to the loop $g(\alpha_h)$, and we claim that

$$(2.3) \quad g(\alpha_h) = \alpha_{\tilde{g} \circ h \circ \tilde{g}^{-1}}$$

For the expression $\alpha_{\tilde{g} \circ h \circ \tilde{g}^{-1}}$ to make sense, we first check that the composition $\tilde{g} \circ h \circ \tilde{g}^{-1}$ is a deck transformation of $\pi_{univ} : \widetilde{M}_{univ} \rightarrow M$:

$$\begin{aligned} \pi_{univ} \circ (\tilde{g} \circ h \circ \tilde{g}^{-1}) &= g \circ \pi_{univ} \circ h \circ \tilde{g}^{-1} \\ &= g \circ \pi_{univ} \circ \tilde{g}^{-1} \\ &= g \circ g^{-1} \circ \pi_{univ} = \pi_{univ}. \end{aligned}$$

To prove the claim, it is enough to compare actions of both sides in (2.3) on the fiber $\pi_{univ}^{-1}(x_0)$ since the covering is regular. Take any point y in the fiber $\pi_{univ}^{-1}(x_0)$. We consider the path $\widetilde{\alpha}_h$ which is the lift of the loop α_h starting from y . Then, its end point gives

$$h(y) = \widetilde{\alpha}_h(1).$$

Hence, $g(\alpha_h)$ is a loop based at x_0 , and we get a corresponding deck transformation, say $g(h)$. Let $\widetilde{g(\alpha_h)}$ be the lift of $g(\alpha_h)$ starting from y . Then, $\alpha_{g(h)} = g(\alpha_h)$ sends y to $(\widetilde{g(\alpha_h)})(1)$. To get (2.3), we have to show that

$$(\widetilde{g(\alpha_h)})(1) = \tilde{g}(h(\tilde{g}^{-1}(y))).$$

Let $\widetilde{\alpha}_h'$ be the lifting of α_h which begins at $\tilde{g}^{-1}(y)$ instead of y . $\tilde{g}(\widetilde{\alpha}_h')$ is the lifting of $g(\alpha_h)$ which starts from y because

$$\tilde{g}(\widetilde{\alpha}_h')(0) = \tilde{g} \cdot (\tilde{g}^{-1}(y)) = y,$$

and

$$\pi \circ (\tilde{g}(\widetilde{\alpha}_h')) = g(\pi \circ \widetilde{\alpha}_h') = g(\alpha_h).$$

Now

$$(\widetilde{g(\alpha_h)})(1) = \tilde{g}(\widetilde{\alpha}_h'(1)) = \tilde{g}(h(\tilde{g}^{-1}(y))),$$

which proves the claim (2.3).

By the previous lemma, $g(\alpha_h)$ and α_h are the same elements modulo $\text{Ker}I_\eta$. Projecting down (2.3) from \widetilde{M}_{univ} to \widetilde{M} , we obtain for $h \in \Gamma$ that

$$\tilde{g} \circ h \circ \tilde{g}^{-1} = h.$$

on \widetilde{M} . □

We will give more geometric proof of Lemma 2.4 in Subsection 3.2. The G -action on Γ induces the trivial G -action on $\Lambda_{[\eta]}$ as well.

Note that $\pi^*\eta$ is exact by construction. So, we can find a smooth function $\tilde{f} : \tilde{M} \rightarrow \mathbb{R}$ such that

$$d\tilde{f} = \pi^*\eta.$$

From the transversality assumption on η , \tilde{f} is a Morse function on \tilde{M} .

Lemma 2.5. \tilde{f} is G -invariant.

Proof. Since η is G -invariant and π is G -equivariant, we have for each $g \in G$,

$$d(\tilde{g}^*\tilde{f} - \tilde{f}) = \tilde{g}^*d\tilde{f} - d\tilde{f} = \tilde{g}^*(\pi^*\eta) - d\tilde{f} = \pi^*(g^*\eta) - d\tilde{f} = \pi^*\eta - d\tilde{f} = 0.$$

As we assumed that M is connected, there is a constant c_g such that for all $x \in M$,

$$(2.4) \quad c_g = \tilde{f}(g \cdot x) - \tilde{f}(x).$$

Putting $g^i \cdot x$ in the place of x , we get

$$(2.5) \quad \begin{cases} c_g = \tilde{f}(g^2 \cdot x) - \tilde{f}(g \cdot x) \\ c_g = \tilde{f}(g^3 \cdot x) - \tilde{f}(g^2 \cdot x) \\ \vdots \\ c_g = \tilde{f}(x) - \tilde{f}(g^{|g|-1} \cdot x) \end{cases}$$

since $g^{|g|} = 1$ where $|g|$ is the order of $g \in G$. By summing up, we have $|g|c_g = 0$ and, hence $c_g = 0$. We conclude that $g^*\tilde{f} = \tilde{f}$. In fact, with the assumption 2.1, we have $c_g = \tilde{f}(g \cdot x_0) - \tilde{f}(x_0) = 0$. But the above argument works without the assumption 2.1. \square

Lemma 2.6. The isotropy group $G_{\tilde{x}}$ is the same as G_x for all $x \in M$.

Proof. It is easy to see that $G_{\tilde{x}} \subset G_x$. For $g \in G_x$, $g \cdot \tilde{x}$ and \tilde{x} may not be homotopic (regarding \tilde{x} as a path from x_0 to x), but they differ by the $\text{Ker}I_\eta$ -action. More precisely $\tilde{x} \star (g\tilde{x})_- \in \text{Ker}I_\eta$ sends $g \cdot \tilde{x}$ to \tilde{x} . \square

2.2. Morse theory for global quotients

Before constructing the G -Novikov complex, we briefly recall the construction of Morse complexes for global quotients from [13] (using the language of orientation spaces in [37]).

For the global quotient orbifold $[M/G]$, consider a G -invariant Morse-Smale function $f : M \rightarrow \mathbb{R}$, and denote by $\bar{f} : M/G \rightarrow \mathbb{R}$, the induced map on the quotient. G -action sends a critical point of f to another critical point, but this naive group action on $\text{crit}(f)$ is not the right action to consider as observed in [13].

For the critical point p , consider the unstable manifold $W^u(p)$ of the negative gradient flow of f , and its tangent space $T_p W^u(p)$. In [13], we observed that G should act on the determinant bundle of “unstable directions”, $\wedge^{\text{top}}(T_p W^u(p))$ of each critical point. (We remark that such determinant line bundles also appear for Morse complexes of Morse-Bott functions.)

Definition 2.7. Orientation space Θ_p^- at p is defined as

$$\Theta_p^- := \wedge^{\text{top}} T_p W_f^u(p).$$

Without a group action, such additional data are always trivial. However when there is a group action, G may act on orientation spaces in a non-trivial way. This is a crucial difference, in the sense that the critical point p is fixed by the G_p -action, but p together with its orientation space may not be fixed by the G_p -action, as G_p may reverse the orientation of unstable directions (such a critical point was called non-orientable in [13]). Hence, when we take the G -invariant part, non-orientable critical points disappear, and rightfully so since the topology of the sublevel sets of the orbifold does not change at such a critical point (see [31]). We refer readers to [13] for more details.

Orientation spaces naturally arise also when we consider the assignment of signs for each isolated gradient flow in the definition of the boundary operator of Morse complexes. Consider two critical points p and q with Morse indices $i(p) = i(q) + 1$. Then, the space $\widetilde{\mathcal{M}}(p, q)$ of gradient flows between p and q can be identified with

$$(2.6) \quad \widetilde{\mathcal{M}}(p, q) = W^u(p) \cap W^s(q),$$

where $W^s(q)$ is the stable manifold of q for $-\nabla f$.

In terms of orientations, (2.6) can be written as follows: For $u \in \widetilde{\mathcal{M}}(p, q)$,

$$(2.7) \quad \wedge^{\text{top}} T_u \widetilde{\mathcal{M}}(p, q) \cong \Theta_p^- \otimes (\Theta_q^-)^\vee,$$

where $(\Theta_q^-)^\vee$ is the dual space with respect to the canonical pairing $(\Theta_q^-)^\vee \otimes (\Theta_q^-) \rightarrow \mathbb{R}$. In the isomorphism (2.7), two copies of $\wedge^{\text{top}} TM$ should appear but cancelled. These copies come from the relation of $W^s(q)$ and $W^u(q)$, and from taking the intersection of them in M . (see (12.2) of [37] for the Floer

theoretic analogue). Therefore, this also explains why orientation spaces Θ_p^- 's are needed to define a G -action.

Here, Θ_p^- is a one dimensional real vector space, and we will be only concerned about the sign of the elements of these vector spaces, not the actual magnitudes when identified with \mathbb{R} . Hence, we use the normalization convention, following [37] as explained in the introduction. We set up the Morse complex of f as follows.

Definition 2.8. Define

$$(2.8) \quad C_k(M, f) = \bigoplus_{\text{ind}(p)=k} |\Theta_p^-|_R$$

We recall that the differential of the Morse complex can be understood as follows. The time translation of $\widetilde{\mathcal{M}}$ gives an element in $\wedge^{\text{top}} T_u \widetilde{\mathcal{M}}(p, q)$, and from the equality (2.7), this determines an isomorphism $c_u : \Theta_q^- \rightarrow (\Theta_p^-)$. We use $|c_u^{-1}|_R$ to define a boundary map

$$(2.9) \quad \partial^{p,q} : \sum_u |c_u^{-1}|_R : |\Theta_p^-|_R \rightarrow |\Theta_q^-|_R.$$

This is a coordinate-free way of writing the usual boundary operator of the Morse complex. Namely, a trajectory has an induced orientation from the transversal intersection $W^u(p) \cap W^s(q)$ and we assign $+1$ if it agrees with the direction of the flow itself (the time translation) and -1 otherwise.

Now, we can consider a natural G -action on the Morse complex $C_*(M, f)$. It is not hard to see that the G -action commutes with the Morse differential in this new setting. Hence, we can take the G -invariant part $C_*(M, f)^G$, which is the Morse complex for $[M/G]$. Its homology is isomorphic to the singular homology of the quotient space of $[M/G]$ with R -coefficients for $R \supset \Theta$. Here Θ is needed since over \mathbb{Z} , local Morse data are much more complicated.

One difficulty of building up G -Morse theory is the equivariant transversality problem. Namely, it is hard to make a generic perturbation of either the Morse function or the metric so that it becomes both Morse-Smale and G -invariant. There are two ways to overcome this issue. In [13], we introduced the notion of weak group actions on Morse-complexes, for a generic Morse-Smale function f , which is not G -invariant. It can be also applied in this setting, and later we will use this idea to define the equivariant Fukaya category for an exact symplectic manifold.

Another way is to work with a G -invariant Morse function which is not necessarily Morse-Smale, and use the multi-valued perturbation scheme such

as Kuranishi structure([24]). We will use this approach in the general case of Floer theory to achieve equivariant transversality. We also need $\Theta \subset R$ for this method. From now on, we assume that \tilde{f} on \tilde{M} is of Morse-Smale type, and leave more general case to one of the above two methods.

2.3. Constructions of G -Novikov complexes

We spell out how to set up the G -equivariant Novikov chain complex of η under Assumption 2.1. We denote by $crit(\tilde{f})$ the set of critical points of \tilde{f} . We will use the normalization $|\Theta|_R$ defined in the introduction.

Definition 2.9. We define the Novikov chain complex of M with respect to η , $CN_*(M; \eta)$ as follows: the graded R -vector space $CN_*(M; \eta)$ is defined by

$$CN_*(M; \eta) := \left\{ \sum_i x_{\tilde{p}_i} \mid x_{\tilde{p}_i} \in |\Theta_{\tilde{p}_i}^-|_R \text{ satisfying } \diamond \right\},$$

where \diamond is the condition that for each $c \in \mathbb{R}$, the following set is finite:

$$\{i : x_i \neq 0, \tilde{f}(\tilde{p}_i) < c\}.$$

The boundary operator δ on $CN_*(M; \eta)$ is defined by counting gradient flow lines of \tilde{f} in \tilde{M} as in G -Morse theory (2.9).

Note that the deck transformation group Γ preserves the set $crit(\tilde{f})$, and this gives $CN_*(M; \eta)$ a $\Lambda_{[\eta]}$ -module structure,

$$(2.10) \quad \phi : \Lambda_{[\eta]} \times CN_*(M; \eta) \rightarrow CN_*(M; \eta).$$

More precisely, consider a generator h of $\Lambda_{[\eta]}$. i.e. an element h of $\Gamma = \pi_1(M)/\text{Ker}I_\eta$. Then the scalar multiplication of h to $\tilde{p} \in crit(\tilde{f})$ is simply the action image $h(\tilde{p})$. Then, $\Lambda_{[\eta]}$ -module structure on $CN_*(M; \eta)$ is given as follows. As $\Theta_{\tilde{p}}^-$ is defined by $\Lambda^{top}T_{\tilde{p}}W_f^u(\tilde{p})$ and h sends $W_f^u(\tilde{p})$ to $W_f^u(h(\tilde{p}))$, we have an isomorphism (denoted by the same letter)

$$h : \Theta_{\tilde{p}}^- \rightarrow \Theta_{h(\tilde{p})}^-.$$

Lemma 2.10. *We have an induced G -action on $CN_*(M; \eta)$, which is $\Lambda_{[\eta]}$ -linear. The differential δ is G -equivariant.*

Proof. As \tilde{f} being G -invariant, G acts on the set $\text{crit}(\tilde{f})$. Thus, each g induces an isomorphism

$$g : \Theta_{\tilde{p}}^- \rightarrow \Theta_{g(\tilde{p})}^-.$$

as before. Hence, we obtain a G -action on generators of $CN_*(M; \eta)$ over $\Lambda_{[\eta]}$. Note that G and Γ actions commute (since their actions on \tilde{M} commute) and the lemma follows. The proof of G -equivariancy follows from (2.7) and the definition of δ . \square

Definition 2.11. We call the complex $CN_*(M; \eta)$ equipped with the above G -action, the G -equivariant Novikov complex of (M, η) . Its G -invariant part $CN_*^G(M; \eta)$ (which is a $\Lambda_{[\eta]}$ -module) is called the Novikov complex of $([M/G], \bar{\eta})$ where $\bar{\eta}$ is the induced 1-form on $[M/G]$.

Here, the $\Lambda_{[\eta]}$ -module structure of $CN_*^G(M; \eta)$ is given by taking the G -invariant part of (2.10) (recall that the G -action is $\Lambda_{[\eta]}$ -linear): $\phi^G : \Lambda_\eta \times CN_*^G(M; \eta) \rightarrow CN_*^G(M; \eta)$, and the boundary δ is $\Lambda_{[\eta]}$ -linear ([34]). In conclusion, we get

$$HN_*^G(M, \eta) := H_*(CN_*^G(M; \eta), \delta),$$

which is a module over $\Lambda_{[\eta]}$.

What actually happens in taking the G -invariant part is as follows. For a critical point \tilde{p} of \tilde{f} , consider the isotropy group $G_p (= G_{\tilde{p}})$. If the G_p -action on $\Theta_{\tilde{p}}^-$ is orientation preserving, then this provides a non-trivial element in the G -invariant part. If some element g of G_p reverses the orientation of $\Theta_{\tilde{p}}^-$, then exactly the half of G_p reverses the orientations of $W_{\tilde{f}}^u(\tilde{p})$. Thus the sum of G -action images of $(\tilde{p}, \Theta_{\tilde{p}}^-)$ becomes zero by the cancellation, and hence do not contribute to the G -invariant part of the Novikov complex. We refer readers to [13] for more details on related phenomenon.

3. General G -Novikov theory

In this section, we construct a G -Novikov complex in the general case without assumption 2.1. The main difficulty is that the construction of covering spaces (as spaces of homotopy classes of paths from a chosen base point) is not compatible with the G -action. Indeed, the G -action may move the chosen base point to another point.

For this, we will introduce the notion of *energy zero subgroup* G_η , and define its action on Novikov complexes. If $G = G_\eta$, we can define equivariant

and orbifolded theory from this G_η action. But in the general case that $G \neq G_\eta$, we need to use a different Novikov ring, what is called Λ^{orb} . In fact, the most natural way to view it is to consider the orbifold fundamental group of the global quotient orbifold $[M/G]$ and the orbifold analogue of the Novikov covering construction. We will explain how G_η , and Λ^{orb} arise in this orbifold setting. Hence, if $G \neq G_\eta$, we cannot define G -equivariant theory, but we can define G -orbifolded theory, by taking G_η -invariant parts of the Novikov complex, with Novikov ring given by Λ^{orb} .

3.1. Energy zero subgroups and their actions on Novikov coverings

We first take a generic point $x_0 \in M$ such that the isotropy group at x_0 of the G -action is trivial. That is, $g \cdot x_0 \neq x_0$ for all $g \neq 1 \in G$. As the G -action on M is effective, such x_0 always exists. Let η be a G -invariant Morse 1-form η on M and consider the universal covering space \widetilde{M}_{univ} and Novikov covering $\pi : \widetilde{M} \rightarrow M$ obtained by $\widetilde{M} = \widetilde{M}_{univ}/\text{Ker}I_\eta$ where $I_\eta(\alpha) = \int \alpha^* \eta$ for $\alpha \in \pi_1(M, x_0)$.

Now, we take the group action into account. Note that the G -action on M does not induce a G -action on \widetilde{M} : consider $\tilde{x} \in \widetilde{M}$ with $\pi(\tilde{x}) = x \in M$. Then, \tilde{x} is an equivalent class of paths from x_0 to x . The naive G -action sends \tilde{x} to $g(\tilde{x})$, which is a homotopy class of paths from $g \cdot x_0$ to $g \cdot x$. This path is not an element of \widetilde{M} since it does not start from x_0 .

Definition 3.1. A subgroup G_η of G consists of an element $g \in G$ such that there exist a path γ_g from x_0 to $g \cdot x_0$, with

$$\int \gamma_g^* \eta = 0.$$

We call G_η the *energy zero* subgroup of G for η and a path γ_g an *energy zero path*.

To see that G_η indeed forms a subgroup, consider $g, h \in G_\eta$ with energy zero paths γ_g and γ_h respectively. Then, we can take an energy zero path for $gh \in G_\eta$ to be the concatenation

$$\gamma_{gh} = \gamma_g \star g(\gamma_h).$$

Remark 3.2. A priori, such energy zero paths may not always exist (i.e. $G_\eta \neq G$ in general). For example, consider $G = \mathbb{Z}/3$ -action defined by the rotation on S^1 and $d\theta$ a G -invariant 1-form on S^1 . Then, $G_\eta = \{id\} \neq G$.

By considering the energy zero subgroup G_η , we can define a G_η -action on the Novikov covering \widetilde{M} as below.

Definition 3.3. Given $\tilde{x} \in \widetilde{M}$ (regarded as a class of paths in M) and $g \in G_\eta$ with an energy zero path γ_g , we define the action of g on \tilde{x} as the concatenation of γ_g with the naive g -action image of \tilde{x} :

$$(3.1) \quad g \cdot \tilde{x} := \gamma_g \star g(\tilde{x}).$$

Lemma 3.4. *This gives a well-defined G_η -action on \widetilde{M} .*

Proof. For a different choice of an energy zero path γ'_g for g , the concatenation $\gamma_g \star (\gamma'_g)_-$ defines a loop in $\text{Ker} I_\eta$ where $\gamma_-(t) = \gamma(1 - t)$ for a path γ . Then, two elements $\gamma_g \star (g(\tilde{x}))$, and $\gamma'_g \star (g(\tilde{x}))$ differ by an action of $\text{Ker} I_\eta$, hence the action of G_η on \widetilde{M} is well-defined. Also it is easy to check that $g \cdot (h \cdot \tilde{x}) = gh \cdot \tilde{x}$ for $g, h \in G_\eta$. \square

If one tries to define a g -action similarly for an element $g \in G \setminus G_\eta$ (by taking a path γ_g from x_0 to $g(x_0)$), then it is straightforward to see that the relation $g^{|g|} = id$ cannot hold for the action of g . Indeed, attaching γ_g keeps increasing (or decreasing) the energy.

Now let us closely look into the G_η -action \widetilde{M} . From the construction, the projection $\pi : \widetilde{M} \rightarrow M$ is a G_η -equivariant map:

$$\pi(g \cdot \tilde{x}) = g \cdot \pi(\tilde{x}).$$

The pull-back $\pi^*\eta$ is exact by the definition of \widetilde{M} and hence we can choose $\tilde{f} : \widetilde{M} \rightarrow \mathbb{R}$ so that $d\tilde{f} = \pi^*\eta$ as before. We can proceed as in Lemma 2.5 to obtain

Lemma 3.5. $\tilde{f} : \widetilde{M} \rightarrow \mathbb{R}$ is G_η -invariant.

As we assumed that M is connected, we can find interesting properties of G_η :

Lemma 3.6. G_η is a normal subgroup of G .

Proof. For $h \in G_\eta$ and $g \in G$, we want to show that ghg^{-1} lies in G_η . So, we need to find an energy zero path from a base point x to $(ghg^{-1}) \cdot x$. Set $y = g^{-1} \cdot x$. Then, it suffices to find such a path from y to $h \cdot y$. Choose any path δ from y to x and let γ_h be an energy zero path from x to $h \cdot x$. Then, it is easy to check that $\delta \star \gamma_h \star h(\delta)_-$ from y to $h \cdot y$ has energy zero. \square

Lemma 3.7. *For any $y \in M$, the isotropy group G_y is a subgroup of G_η .*

Proof. We fix $y \in M$, and $g \in G_y$. Since M is connected, we can choose a path α from x_0 to y . Then, $g(\alpha)$ defines a path from $g \cdot x_0$ to $g \cdot y (= y)$. Then, we get a path from x_0 to $g \cdot x_0$ by

$$\gamma := \alpha \star (g \cdot \alpha)_-$$

Note that

$$I_\eta(\gamma) = I_\eta(\alpha) + I_\eta((g \cdot \alpha)_-) = I_\eta(\alpha) - I_\eta(\alpha) = 0$$

Thus, γ has zero energy and realizes g as an element of G_η . This implies that $G_y \subset G_\eta$ for all y . □

Corollary 3.8. *If M has a point, say x_1 , which is fixed by the whole G -action, then $G_\eta = G$.*

Proof. Take y to be x_1 , and apply Lemma 3.7. □

3.2. Deck transformations and G_η -actions on Novikov complexes

Lemma 3.9. *The G_η -action on \widetilde{M} commutes with the action of the deck transformation group $\Gamma = \pi_1(M)/\text{Ker}I_\eta$.*

Proof. The proof of Lemma 2.4 (for the case with a G -fixed base point) extends to this general case. But here, we give a geometric proof of it using the G_η -action (3.1).

Let $h \in \Gamma$ be represented by a loop α_h at x_0 . If γ_g realizes $g \in G_\eta$ (i.e. $\gamma_g(1) = g \cdot x_0$ and $I_\eta(\gamma_g) = 0$), then $\gamma_{g^{-1}} = g^{-1} \cdot (\gamma_g)_-$ realizes g^{-1} . Any point \tilde{x} in \widetilde{M} can be thought of as a (homotopy class of) path from x_0 modulo $\text{Ker}I_\eta$ -action. Then, we have path representations of elements in \widetilde{M} as follows:

- (a) $g \cdot (h \cdot \tilde{x})$ is represented by the concatenation $\gamma_g \star (g \cdot \alpha_h) \star (g \cdot \tilde{x})$.
- (b) $h \cdot (g \cdot \tilde{x})$ is represented by the concatenation $\alpha_h \star \gamma_g \star (g \cdot \tilde{x})$
- (c) The difference between (a) and (b) is represented by $\gamma_g \star (g \cdot \alpha_h) \star (\gamma_g)_- \star (\alpha_h)_-$.

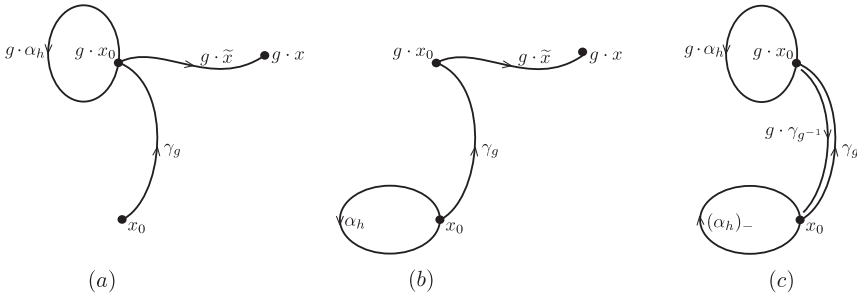

Figure 1: (a) $g \cdot (h \cdot \tilde{x})$ (b) $h \cdot (g \cdot \tilde{x})$ (c) $g \cdot (h \cdot \tilde{x}) - h \cdot (g \cdot \tilde{x})$.

Since η is g -invariant

$$\int_{\alpha_h} \eta + \int_{g \cdot (\alpha_h)_-} \eta = 0,$$

We conclude that (c) has energy zero, or equivalently

$$g \cdot (h \cdot \tilde{x}) = h \cdot (g \cdot \tilde{x}).$$

□

Since the G -action on M is orientation preserving, it is easy to see that G_η preserves the induced orientation on \widetilde{M} . Here is a simple lemma on the relationship between isotropy groups in M and \widetilde{M} analogous to Lemma 2.6

Lemma 3.10. *Consider $\tilde{x} \in \widetilde{M}$ with $\pi(\tilde{x}) = x$. Then the isotropy group $(G_\eta)_{\tilde{x}}$ at \tilde{x} in G_η is given by*

$$(3.2) \quad (G_\eta)_{\tilde{x}} = G_x \cap G_\eta = G_x.$$

Proof. The second equality in (3.2) follows from the lemma 3.7. We only prove the first equality, here. For $g \in G_\eta$, we choose an energy zero path γ_g from x_0 to $g \cdot x_0$ in M . Then, if $g \in (G_\eta)_{\tilde{x}}$, then $g \cdot \tilde{x}$ (which is represented by $\gamma_g \star g(\tilde{x})$) has the same end point as \tilde{x} . This means that g is an element of G_x .

Conversely, if g fixes x , and admits an energy zero path γ_g , then both $\gamma_g \star g(\tilde{x})$ and \tilde{x} is a path from x_0 to x in M , and I_η vanishes on $\gamma_g \star g(\tilde{x}) \star \tilde{x}_-$. Thus $g \cdot \tilde{x}$ and \tilde{x} differ by an action of $\text{Ker} I_\eta$, which proves that $g \in (G_\eta)_{\tilde{x}}$. □

To define a G -equivariant Novikov complex, let us first assume that $G = G_\eta$, and postpone the study of general case to the next subsection. We define the Novikov chain complex as in Definition 2.9, and Novikov ring $\Lambda_{[\eta]}$ as in (2.2). By proceeding as before, we obtain

Proposition 3.11. *Assume that the induced $G(= G_\eta)$ -invariant function $\tilde{f} : \tilde{M} \rightarrow \mathbb{R}$ is of Morse-Smale type. Then, we have an induced G -action on the Novikov complex $(CN_*(M; \eta), \delta)$ which is $\Lambda_{[\eta]}$ -linear (i.e. G -action commutes with $\Lambda_{[\eta]}$).*

This defines the G -equivariant Novikov complex of (M, η) . By taking the G -invariant part of $CN_*(M; \eta)$, we get the chain complex

$$(CN_*^G(M; \eta), \delta),$$

which should be considered as Novikov homology of the orbifold $([M/G], \bar{\eta})$ with respect to the induced 1-form $\bar{\eta}$. This construction agrees with the previous construction of Novikov complex with a G -fixed point by Corollary 3.8, and we leave the detailed check as an exercise.

When $G \neq G_\alpha$, proper definition of orbifolded Novikov complex is more involved as we need to introduce orbifold Novikov ring $\Lambda_{[\eta]}^{orb}$.

3.3. Orbifold Novikov ring $\Lambda_{[\eta]}^{orb}$ and orbifold Novikov complex

First, we explain how the energy zero subgroup G_η naturally arises from the orbifold setting. We give a brief review on the orbifold fundamental group $\pi_1^{orb}([M/G])$.

We call a continuous map $\alpha : [0, 1] \rightarrow M$ a generalized loop based at x_0 if $\alpha(0) = x_0$ and $\alpha(1) = g_\alpha \cdot \alpha(0)$. i.e. it is a loop up to G -action. Note that a genuine loop at x_0 is obviously a generalized loop. Since x_0 is generic, g_α is uniquely determined from α .

Two generalized loops α and β (based at x_0) are homotopic if

- $\alpha(1) = \beta(1)$.
- There is a homotopy H between α and β relative to end points.

We write $\alpha \sim \beta$ for such homotopy relation.

Two generalized loops can be multiplied as follows.

$$(3.3) \quad \alpha \cdot \beta = \alpha \star g_\alpha(\beta).$$

where \star denotes the concatenation of two paths as before.

The set of homotopy classes of generalized loops (based at x_0), denoted by $\pi_1^{orb}([M/G], \bar{x}_0)$, has a group structure induced by (3.3). One can also show that $\alpha^{-1} = g_\alpha^{-1}(\alpha_-)$ gives the inverse of $[\alpha]$, where $\alpha_-(t) = \alpha(1 - t)$.

We have a group homomorphism $e : \pi_1^{orb}([M/G]) \rightarrow G$ defined by

$$e([\alpha]) = g_\alpha.$$

It is easy to see that

$$\text{Ker } e = \pi_1(M, x_0).$$

Thus, we have the following short exact sequence of groups which is non-split in general.

$$(3.4) \quad 1 \longrightarrow \pi_1(M) \longrightarrow \pi_1^{orb}([M/G]) \xrightarrow{e} G \longrightarrow 1.$$

The map e is surjective since we assumed that M is connected.

Lemma 3.12. *If M has a point, say x_1 , which is fixed by the whole G -action, then orbifold fundamental group can be written as a semi-direct product:*

$$\pi_1^{orb}([M/G]) \cong G \ltimes \pi_1(M).$$

Proof. Recall that the statement of the lemma is equivalent to the existence of a splitting of the extension (3.4). Thus, we need to find a homomorphism $\phi : G \rightarrow \pi_1^{orb}([M/G])$ such that $e \circ \phi = id$ on G . Now, if G fixes x_1 , we can construct ϕ as follows. Take a path $\gamma : [0, 1] \rightarrow M$ such that $\gamma(0) = x_0$ and $\gamma(1) = x_1$. For each $g \in G$, $g(\gamma)$ is a path from $g(x_0)$ to x_1 . Thus, consider the concatenation of two paths

$$\phi(g) := \gamma \star g(\gamma_-),$$

which is a generalized loop starting from x_0 ending at $g(x_0)$. It is easy to check that ϕ is a homomorphism, and $e \circ \phi = id$. □

It is well-known that the most of the covering theory extends to the case of orbifolds if one considers orbifold fundamental group, orbifold covering and orbifold universal covering. (see for example Takeuchi [41]). The orbifold universal covering for $[M/G]$ is given by the universal covering \widetilde{M}_{univ} of M , with the projection maps $\widetilde{M}_{univ} \rightarrow M \rightarrow M/G$. And $\pi_1^{orb}([M/G])$ becomes the deck transformation group of $\widetilde{M}_{univ} \rightarrow M/G$, whose action can be written as follows.

Definition 3.13. We define the (left) action of $\pi_1^{orb}([M/G])$ on \widetilde{M}_{univ} as the concatenation of paths: for $\gamma \in \pi_1^{orb}([M/G])$ with $\gamma(1) = g_\gamma(x_0)$, and for a path \tilde{x} from x_0 to x , as an element of \widetilde{M}_{univ} , we define

$$\gamma \cdot \tilde{x} := \gamma \star g_\gamma(\tilde{x}).$$

Recall η is a Morse 1-form on M , which is G -invariant. We denote by $\bar{\eta}$ the induced 1-form on the quotient M/G .

Definition 3.14. We define $I_\eta^{orb} : \pi_1^{orb}([M/G]) \rightarrow \mathbb{R}$ as follows:

$$I_\eta^{orb}(\alpha) := \int_0^1 \alpha^* \eta \quad \text{for } \alpha \in \pi_1^{orb}([M/G]).$$

This defines a group homomorphism since η is G -invariant.

We consider the subgroup $\text{Ker} I_\eta^{orb}$, the kernel of I_η^{orb} , which acts on the orbifold universal covering \widetilde{M}_{univ} , and consider the quotient orbifold $[\widetilde{M}_{univ}/\text{Ker} I_\eta^{orb}]$. An analogue of Novikov covering $\widetilde{M} \rightarrow M$ in section 2 would be the orbifold covering

$$[\widetilde{M}_{univ}/\text{Ker} I_\eta^{orb}] \rightarrow [M/G].$$

But it is cumbersome to work directly with $[\widetilde{M}_{univ}/\text{Ker} I_\eta^{orb}]$. For example, $\text{Ker} I_\eta^{orb}$ is discrete but may not be finite in general. Alternatively, we find another presentation of the orbifold $[\widetilde{M}_{univ}/\text{Ker} I_\eta^{orb}]$, which is much easier to understand.

Remark 3.15. Similarly to 3.12, if there exists a G -fixed point, then we have

$$\text{Ker} I_\eta^{orb}([M/G]) \cong G \ltimes \text{Ker} I_\eta.$$

Before we give the actual construction, it may be helpful to first explain the formalism. Consider the group B acting effectively on a manifold X , and let A be a normal subgroup of B . Then, A , B , and the quotient group $C = B/A$ form an exact sequence $1 \rightarrow A \rightarrow B \rightarrow C \rightarrow 1$. Note that the B -action on X induces the B/A -action on the quotient space X/A because A

is a normal subgroup. Also the quotient satisfies

$$(3.5) \quad (X/A)/(B/A) \cong X/B.$$

Thus instead of X/B , we will consider X/A and its quotient by the group $C = B/A$, and the benefit is that $X/A, B/A$ are simpler than X and B (also in our case below X/A will be still a manifold).

Now, we put $B = \text{Ker}I_\eta^{orb}$, and $A = \text{Ker}I_\eta$ and consider the following diagram of subgroups of fundamental groups.

$$(3.6) \quad \begin{array}{ccccccc} 1 & \longrightarrow & \text{Ker}I_\eta & \longrightarrow & \text{Ker}I_\eta^{orb} & \xrightarrow{e_\eta} & G_\eta \longrightarrow 1 \\ & & \downarrow \leq & & \downarrow \leq & & \downarrow \leq \\ 1 & \longrightarrow & \pi_1(M, x_0) & \longrightarrow & \pi_1^{orb}([M/G]) & \xrightarrow{e} & G \longrightarrow 1 \\ & & \downarrow & & \downarrow & & \downarrow \\ 1 & \longrightarrow & \Gamma & \longrightarrow & \Gamma^{orb} & \longrightarrow & G/G_\eta \longrightarrow 1 \end{array}$$

Definition 3.16. We define G_η to be the quotient group $\text{Ker}I_\eta^{orb}/\text{Ker}I_\eta$. G_η can be identified with a subgroup of G via the map

$$\text{Ker}I_\eta^{orb}/\text{Ker}I_\eta \rightarrow \pi_1^{orb}([M/G])/\pi_1(M) = G.$$

Hence, we have $C = \text{Ker}I_\eta^{orb}/\text{Ker}I_\eta$ in the formalism above. From the diagram (3.6), we can correspondingly construct a diagram of covering spaces as follows:

$$(3.7) \quad \begin{array}{ccc} \widetilde{M}_{univ} & \xrightarrow{id} & \widetilde{M}_{univ} \\ \downarrow & & \downarrow \\ \widetilde{M} = \widetilde{M}_{univ}/\text{Ker}I_\eta & \xrightarrow{/G_\eta} & [\widetilde{M}_{univ}/\text{Ker}I_\eta^{orb}] \\ \downarrow & & \downarrow \\ M & \xrightarrow{/G} & [M/G] \end{array}$$

Here $\widetilde{M} = \widetilde{M}_{univ}/\text{Ker}I_\eta$, which is the Novikov covering space considered in the previous section. From the discussion above, the identity (3.5) becomes

$$(3.8) \quad [\widetilde{M}/G_\eta] \cong [\widetilde{M}_{univ}/\text{Ker}I_\eta^{orb}].$$

Note that \widetilde{M} is a manifold (it is a covering of M), and we have a presentation of the orbifold which involves simpler group G_η than $\text{Ker}I_\eta^{orb}$. This provides an explanation of G_η , and should extend to the general orbifold case.

In the case when $G \neq G_\eta$, there is a subtle problem with Novikov rings as examined from now on. The deck transformation group for the Novikov cover $[\widetilde{M}_{univ}/\text{Ker}I_\eta^{orb}] \rightarrow [M/G]$ is given by the quotient group

$$\Gamma^{orb} := \pi_1^{orb}([M/G])/\text{Ker}I_\eta^{orb},$$

while the deck transformation group for $\widetilde{M} \rightarrow M$ is given by

$$\Gamma := \pi_1([M/G])/\text{Ker}I_\eta.$$

From the diagram (3.6), we see that the difference of two groups is exactly given by G/G_η . We write the associated Novikov rings as $\Lambda_{[\eta]}^{orb}$ and $\Lambda_{[\eta]}$ respectively as in (2.2). The inclusion $\Gamma \rightarrow \Gamma^{orb}$ gives rise to a map $\Lambda_{[\eta]} \rightarrow \Lambda_{[\eta]}^{orb}$ between the (completions of) group rings.

The Novikov complex is defined in the following way. From the previous construction, we have the Novikov complex $(CN_*(M; \eta), \delta)$ for \widetilde{M} with Novikov coefficients $\Lambda_{[\eta]}$ and the G_η -action on it. Now, we can replace the Novikov coefficients by

$$(3.9) \quad CN_*(M; \eta) \otimes_{\Lambda_{[\eta]}} \Lambda_{[\eta]}^{orb},$$

which still has a G_η -action.

Definition 3.17. We define the orbifolded Novikov complex of $([M/G], \bar{\eta})$ to be

$$(3.10) \quad (CN_*(M; \eta) \otimes_{\Lambda_{[\eta]}} \Lambda_{[\eta]}^{orb})^{G_\eta}$$

For example, let us consider the case that G -action is free. The following proposition shows that the complex in Definition 3.17 is the right Novikov complex for the quotient space of the free action.

Proposition 3.18. *If G acts on M freely, then we have $\Lambda_{[\eta]}^{orb} \cong \Lambda_{[\bar{\eta}]}$ and the following isomorphism of $\Lambda_{[\bar{\eta}]}$ -modules*

$$(CN_*(M; \eta) \otimes_{\Lambda_{[\eta]}} \Lambda_{[\eta]}^{orb})^{G_\eta} \cong CN_*(M/G; \bar{\eta})$$

Proof. Since G acts freely on M

$$(3.11) \quad \pi_1^{orb}([M/G]) \cong \pi_1(M/G), \quad \text{Ker} I_\eta^{orb} \cong \text{Ker} I_{\bar{\eta}}.$$

This gives the desired identification of $\Lambda_{[\eta]}^{orb}$ and $\Lambda_{[\bar{\eta}]}$.

Note that the G_η -action on \widetilde{M} is also free. One can see from the diagram (3.7) that the Novikov covering space of M/G with respect to the Morse 1-form $\bar{\eta}$ is exactly the quotient of \widetilde{M} by the free G_η -action. Therefore, $(CN_*(M; \eta) \otimes_{\Lambda_\eta} \Lambda_\eta^{orb})^{G_\eta}$ is naturally isomorphic to $CN_*(M/G; \bar{\eta})$ which is essentially the Morse chain complex of $\bar{f} : \widetilde{M}/G_\eta \rightarrow \mathbb{R}$ with the Novikov coefficients. \square

3.4. Generalizations

(1) Let us first drop the assumption that M is connected from theorem 3.11. Denote connected components of M by M_i ($1 \leq i \leq k$). i.e. $M = \sqcup_{i=1}^k M_i$. Let us call M_i and M_j , G -related if there exist $x \in M_i$ and $g \in G$ such that $g(x) \in M_j$. This defines an equivalence relation. We divide the index set $\{1, \dots, k\}$ into

$$\{i_{11}, \dots, i_{1a_1}\} \sqcup \dots \sqcup \{i_{j1}, \dots, i_{ja_j}\}$$

using this equivalent relation so that connected components $M_{i_{1l}}, \dots, M_{i_{al}}$ are G -related for any $l = 1, \dots, j$.

To define a group action, we need to make the following assumption.

Assumption 3.19. If we denote by G_{ab} the subgroup of G whose elements preserve the connected component $M_{i_{ab}}$, then we require that

$$(G_{ab})_\eta = G_{ab}.$$

Hence, for any $g \in G_{ab}$ and $x \in M_{i_{ab}}$, there exists an energy zero path γ connecting x and $g(x)$.

As an initial step, consider the construction of the Morse-Novikov complex for the subcollection $M_{i_{1l}}, \dots, M_{i_{al}}$ for a fixed l . Now, we choose base points $x_{0, i_{lb}} \in M_{i_{lb}}$ so that they lie in a single G -orbit. We can consider Novikov-Morse theory on each connected component, with base points given by $x_{0, i_{lb}}$'s.

Then, from the assumption, any g -image of $x_{0, i_{lb}}$ for $g \in G$ can be connected to one of $x_{0, i_{lb'}}$ by energy zero path, say γ_g . Then, we can define the group action as before. Namely, we concatenate γ_g to the front

of the image under the naive group action. Also, one can see that the deck transformation group of one component is isomorphic (by conjugation) to that of the other component, hence the resulting Novikov rings can be identified, which we denote as Λ_l .

One can take the direct sum of Novikov complexes

$$(\oplus_{s=1}^{a_l} CN_*(M_{i_s}; \eta|_{M_{i_s}}), \oplus \delta)$$

so that it admits a natural G -action.

Now, let us illustrate how to add various complexes for different l 's. For this, we need to introduce the universal Novikov ring to properly compare various Novikov rings of different subcollections. Then, we will take completed direct sum over all different subcollections to define the Novikov complex (This is similar to what has been done for Novikov Floer theory in [25], where the case of several connected components of a path space are considered).

The universal Novikov ring is defined by

$$\Lambda = \left\{ \sum a_i T^{\lambda_i} \mid a_i \in \mathbb{R}, \lambda_i \in \mathbb{R}, \lim_{i \rightarrow \infty} \lambda_i = \infty \right\},$$

and the ring homomorphism from $\Lambda_{[\eta]} \rightarrow \Lambda$ by

$$\sum a_i h_i \mapsto \sum a_i T^{I_\eta(h_i)}.$$

For each Novikov complex $CN_*(M_{i_{11}}; \eta)$ with G -action, we can introduce the new Novikov complex of M as

$$\widehat{\oplus}_{l=1}^j CN_*(M_{i_{11}}; \eta) \otimes_{\Lambda_{[\eta]}} \Lambda$$

which admits a G -action also.

(2) We have considered a global quotient orbifold $[M/G]$, and have seen how to set up its Novikov complex by working on \widetilde{M} observing G_η -actions. We can generalize the construction to any effective orbifold if we just use orbifold terms, but it will not be explicit as in the global quotient case. As we will not use it in this paper, we briefly outline the construction. Consider a compact connected oriented orbifold χ with a closed Morse 1-form η on χ . It is straight forward that η defines a homomorphism from $I_\eta : \pi_1^{orb}(\chi) \rightarrow \mathbb{R}$. Then, as before its kernel $\text{Ker} I_\eta^{orb} (\leq \pi_1^{orb}(\chi))$ corresponds to the orbifold covering $\pi : \widetilde{\chi} \rightarrow \chi$ on which $\pi^*\eta$ is an exact 1-form. Note that $\widetilde{\chi}$ is no longer a smooth manifold, but rather an orbifold.

Consider the deck transformation group $\Gamma^{orb} = \pi_1^{orb}(\tilde{\chi})/\text{Ker}I_\eta^{orb}$, and take the (one-sided) completion of the group ring of Γ^{orb} to define $\Lambda_{[\eta]}^{orb}$. Let $f : \tilde{\chi} \rightarrow \mathbb{R}$ be a Morse function on the (orbifold) Novikov cover which integrates $\pi^*\eta$. If f is of Morse-Smale type, we apply the construction in [13] (for general orbifolds) to obtain the orbifold Morse complex of $f : \tilde{\chi} \rightarrow \mathbb{R}$ with $\Lambda_{[\eta]}^{orb}$ -coefficients. $CN_*(\tilde{\chi}; \eta)$ has a natural $\Lambda_{[\eta]}^{orb}$ -module structure and the boundary operator δ which counts gradient trajectories is $\Lambda_{[\eta]}^{orb}$ -linear. We may call the resulting complex the Novikov complex of (χ, η) .

4. Floer-Novikov theory and orientation spaces

We recall the setup of Floer-Novikov theory briefly (following [25]), and also the notion of orientation spaces as well as some gluing formulas for them, which are well-known constructions. In the last subsection, we will provide a detailed explanation on the identification of two orientation spaces arising from two different Γ -equivalent representatives of a generator of a Floer-Novikov complex.

4.1. Floer-Novikov theory

Let L_0 and L_1 be Lagrangian submanifolds of a symplectic manifold (M, ω) , transversally intersecting with each other. Let us assume that both L_0 and L_1 are connected, compact, oriented and also spin for simplicity. Consider the space of paths

$$\Omega(L_0, L_1) = \{l : [0, 1] \rightarrow M \mid l(0) \in L_0, l(1) \in L_1\}.$$

We denote by $\Omega(L_0, L_1; l_0)$ its connected component containing $l_0 \in \Omega(L_0, L_1)$.

We define an 1-form α on $\Omega(L_0, L_1; l_0)$ as follows: for $\xi \in l^*TM = T_l\Omega(L_0, L_1; l_0)$,

$$(4.1) \quad \alpha(\xi) = \int_{[0,1]} \omega(l'(t), \xi(t))dt.$$

The 1-form α is closed but not necessarily exact and hence, one needs to find a suitable Novikov covering for α .

First let us consider the universal covering $\tilde{\Omega}_{univ}(L_0, L_1; l_0)$ of $\Omega(L_0, L_1; l_0)$. A path in $\Omega(L_0, L_1; l_0)$ is a continuous map $w : [0, 1] \times [0, 1] \rightarrow M$ satisfying $w_0(t) = l_0(t)$ and $w_s \in \Omega(L_0, L_1; l_0)$ where $w_s(t) = w(s, t)$. If

$w_1(t) = l(t)$ for $l \in \Omega(L_0, L_1; l_0)$, the homotopy class of such w gives a point in the universal covering space $\tilde{\Omega}_{univ}(L_0, L_1; l_0)$ lying over l .

Denote by $\bar{w}(s, t) := w(1 - s, t)$. Given two elements (w, l) and (w', l') of $\Omega(L_0, L_1; l_0)$, we can glue these to get a loop $C := w \star \bar{w}'$ in $\Omega(L_0, L_1; l_0)$. So we have a loop

$$C : S^1 \times [0, 1] \rightarrow M$$

which satisfies the Lagrangian boundary conditions

$$(4.2) \quad C(s, 0) \in L_0, \quad C(s, 1) \in L_1.$$

We can define its symplectic area $I_\omega(C) = \int_C \omega$ and Maslov index $I_\mu(C)$. The Maslov index I_μ is defined as usual by the difference of the Maslov indices of the loops in the Lagrangian Grassmannian, where the loops are obtained from two boundary components of C after a symplectic trivialization of the pull-back bundle over C . This gives a homomorphism

$$(4.3) \quad (I_\omega, I_\mu) : \pi_1(\Omega(L_0, L_1; l_0)) \rightarrow \mathbb{R} \times \mathbb{Z}.$$

The following definition of the Γ -equivalence between two paths in $\Omega(L_0, L_1; l_0)$ is due to [25].

Definition 4.1. (w, l) and (w', l') are said to be Γ -equivalent if

$$I_\omega(w \star \bar{w}') = 0 = I_\mu(w \star \bar{w}').$$

The set of Γ -equivalence classes forms a covering $\tilde{\Omega}(L_0, L_1; l_0)$ associated to the the following subgroup of $\pi_1(\Omega(L_0, L_1; l_0))$:

$$\text{Ker}(I_\omega, I_\mu) = \text{Ker}I_\omega \cap \text{Ker}I_\mu.$$

Hence the deck transformation group $\Pi(L_0, L_1; l_0)$ of the covering

$$(4.4) \quad \pi : \tilde{\Omega}(L_0, L_1; l_0) \rightarrow \Omega(L_0, L_1; l_0),$$

is given by the quotient $\pi_1(\Omega(L_0, L_1; l_0))/\text{Ker}(I_\omega, I_\mu)$.

By the definition of Γ -equivalences, the homomorphisms I_ω and I_μ give rise to

$$(4.5) \quad (E, \mu) : \Pi(L_0, L_1; l_0) \rightarrow \mathbb{R} \times \mathbb{Z}$$

defined by $E(g) = I_\omega(C)$ and $\mu(g) = I_\mu(C)$. Here, the element $g \in \Pi(L_0, L_1; l_0)$ is represented by a map $C : S^1 \times [0, 1] \rightarrow M$ satisfying (4.2) above. Note that

$\Pi(L_0, L_1; l_0)$ is an abelian group. Indeed (4.5) gives an injective homomorphism onto its image by the definition of Γ -equivalence.

Definition 4.2. We define $\Lambda_k^R(L_0, L_1; l_0)$ as the set of all formal sums

$$\sum_{\substack{h \in \Pi(L_0, L_1; l_0) \\ \mu(h)=k}} a_h[h],$$

such that $a_h \in R$ and

$$|\{h \in \Pi(L_0, L_1; l_0) \mid E(g) \leq C, a_h \neq 0\}| = \infty.$$

We write

$$\Lambda^R(L_0, L_1; l_0) = \bigoplus_k \Lambda_k^R(L_0, L_1; l_0).$$

From the construction, $\pi^*\alpha$ is exact (where π is the covering map in (4.4)). The Floer action functional \mathcal{A} on $\tilde{\Omega}(L_0, L_1; l_0)$ is defined by

$$\mathcal{A}([w, l]) = \int w^*\omega$$

for an element $[w, l]$ in $\tilde{\Omega}(L_0, L_1; l_0)$. Then, the direct computation shows that

$$\pi^*\alpha = -d\mathcal{A}.$$

i.e. the Floer action functional is a Morse function on the Novikov cover which integrates $-\pi^*\alpha$. In short, Floer-Novikov theory is Morse theory of \mathcal{A} on $\tilde{\Omega}(L_0, L_1; l_0)$ with Novikov coefficients $\Lambda^R(L_0, L_1; l_0)$. Critical points of \mathcal{A} are given by $[w, l_p] \in \tilde{\Omega}(L_0, L_1; l_0)$ where l_p is a constant path at $p \in L_0 \cap L_1$.

Like in [25], we work with the universal Novikov ring Λ_{nov} and its subring $\Lambda_{0,nov}$ as coefficient rings for Floer cohomology groups:

$$\Lambda_{nov}(R) = \left\{ \sum_{i=0}^{\infty} a_i T^{\lambda_i} \mid a_i \in R, \lambda_i \in \mathbb{R}, \lim_{i \rightarrow \infty} \lambda_i = \infty \right\},$$

$$\Lambda_{0,nov}(R) = \left\{ \sum_{i=0}^{\infty} a_i T^{\lambda_i} \in \Lambda_{nov}(R) \mid \lambda_i \in \mathbb{R}_{\geq 0} \right\}.$$

Recall for a single Lagrangian L , the associated Novikov ring is defined by

$$\Lambda(L) = \left\{ \sum_{\beta \in \Pi(L)} a_\beta [\beta] \mid \#\{\beta \mid a_\beta \neq 0, E(\beta) < C\} \text{ is finite for each } C \right\}.$$

The homomorphism $I_L : \Lambda(L) \rightarrow \Lambda_{nov}$ given by

$$(4.6) \quad I_L \left(\sum_{\beta \in \Pi(L)} a_\beta [\beta] \right) = \sum_{\beta} a_\beta T^{\int_{\beta} \omega}$$

identifies $\Lambda(L)$ with a subring of the universal Novikov ring. We use the same identification as (4.6) to transfer $\Lambda^k(L_0, L_1; l_0)$ into the universal Novikov coefficients.

4.2. Orientation spaces for Lagrangian Floer theory

We recall orientation spaces for Lagrangian Floer theory. The Cauchy-Riemann (CR for short) operators associated to generators of the Floer-Novikov complex were introduced in [25] for Bott-Morse Lagrangian Floer theory. The index spaces (Definition 4.3) of these operators will be called orientation spaces. Such a notion is a key to analyze Fredholm indices, and orientations of moduli spaces in Lagrangian Floer theory. As so, it is natural to expect that it plays an important role in understanding group actions on Lagrangian Floer theory.

We fix a reference path l_0 , and specify pre-fixed choices of data in what follows. For the chosen reference path $l_0 : [0, 1] \rightarrow M$, we write $l_0(0) = p_0 \in L_0$, $l_0(1) = p_1 \in L_1$. Along the chosen reference path, we choose a fixed path $\lambda_{l_0}(t \mapsto \lambda_{l_0}(t))$, where $\lambda_{l_0}(t)$ is an element of oriented Lagrangian subspace in $T_{l_0(t)}M$ whose end points are given by $\lambda_{l_0}(0) = T_{p_0}L_0$ and $\lambda_{l_0}(1) = T_{p_1}L_1$. We denote

$$\tilde{\lambda}_{l_0} := \bigcup_{t \in [0,1]} \{t\} \times \lambda_{l_0}(t) \rightarrow [0, 1].$$

Before we explain additional choices needed to specify spin structure of the Lagrangian bundle, we recall the definition of the associated CR operator. Consider a critical point $[w, l_p] \in Cr(L_0, L_1; l_0)$ for p a point in the Lagrangian intersection $L_0 \cap L_1$. We choose a representative (w, l_p) of a Γ -equivalence class. We want to define the orientation space $\Theta_{(w, l_p)}^-$ for each representative.

The map w produces a path $\lambda_{w,\lambda_{l_0}}$ of Lagrangian subspaces in TM from T_pL_1 to T_pL_1 by concatenating λ_{l_0} and Lagrangian paths in top and bottom edge of ∂w . More precisely, for

$$(s, t) \in (\{0\} \times [0, 1]) \cup ([0, 1] \times \{0, 1\}) \stackrel{\text{homeo}}{\cong} [0, 1],$$

we get a path $\lambda = \lambda_{w,\lambda_{l_0}}$ such that,

$$(4.7) \quad \lambda(0, t) = \lambda_{l_0}(t), \quad \lambda(i, s) = T_{w(i,s)}L_i \text{ for } i = 0, 1,$$

as drawn in Figure 2.

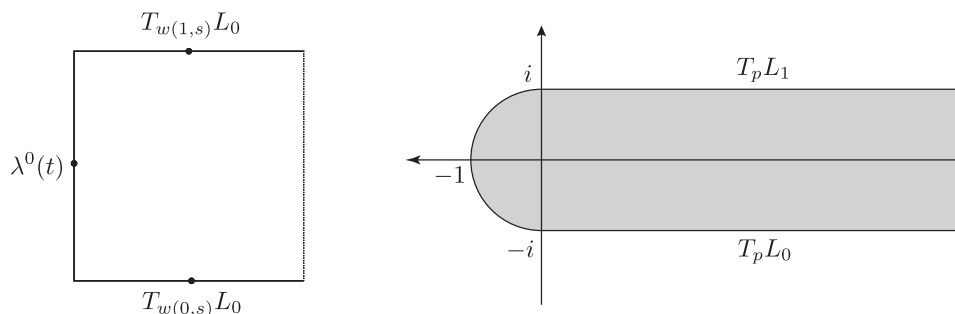

Figure 2: path λ_{w,λ^0} .

Since $[0, 1]^2$ is contractible, we can trivialize w^*TM

$$w^*TM \cong [0, 1]^2 \times T_pM$$

so that λ is a path in the oriented Lagrangian Grassmannian of T_pM . Put

$$Z_- = \{z \in \mathbb{C} \mid |z| \leq 1\} \cup \{z \in \mathbb{C} \mid \operatorname{Re} z \geq 0, |\operatorname{Im} z| \leq 1\}.$$

For $\lambda = \lambda_{w,\lambda_{l_0}}$, one defines a CR operator by

$$\bar{\partial}_{\lambda,Z_-} : W_{\lambda}^{1,p}(Z_-; T_pM) \rightarrow L^p(Z_-; T_pM \otimes \Lambda^{0,1}(Z_-)),$$

whose Lagrangian boundary condition comes from λ . Here, $W_{\lambda}^{1,p}(Z_-; T_pM)$ is the Banach space of $L^{1,p}$ maps $\zeta_- : Z_- \rightarrow T_pM$ with weighted norms:

- 1) $\zeta_-(\tau, i) \in T_pL_i$, where we use $z = \tau + it$

- 2) $\zeta_-(z_-) \in \lambda(t)$, where $z_-(t) = e^{\pi i(-1/2+t)} \in \partial Z_-$
- 3) $\int_{Z_-} e^{\delta|\tau|} (|\nabla \zeta_-|^p + |\zeta_-|^p) d\tau dt < \infty$.

It is well known that $\bar{\partial}_{\lambda, Z_-}$ is a Fredholm operator. See [25] for more details.

Finally, one assigns an orientation space to each generator (w, l_p) as follows.

Definition 4.3. The orientation space $\Theta_{(w, l_p)}^-$ for a pair (w, l_p) is defined as

$$\Theta_{(w, l_p)}^- := \det(\bar{\partial}_{\lambda, Z_-}) = (\wedge^{top} \text{Coker } \bar{\partial}_{\lambda, Z_-})^* \otimes \wedge^{top} \text{Ker } \bar{\partial}_{\lambda, Z_-}.$$

The canonical orientation on the moduli space associated to the CR operators with Lagrangian boundary conditions is determined from the spin structures of the Lagrangian sub-bundles. Later, we will deal with isomorphisms between various orientation spaces, and to find a canonical isomorphism, we need to also specify spin structures of the Lagrangian bundles on the boundary components. Without these, there would be an ambiguity of signs whenever we try to compare, identify and glue orientation spaces. Signs are indeed very crucial information (for example different signs for the group action change the invariant sets).

As in chapter 8 of [25], we fix the following choices of spin data (we will review the notion of spin structure in section 5.1): We choose and fix a trivialization $\sigma : [0, 1] \times \mathbb{R}^n \rightarrow \tilde{\lambda}_{l_0}$, which also provides a trivialization of $T_{p_0}L_0$ and $T_{p_1}L_1$. The latter trivialization $\sigma_{t=i} : \mathbb{R}^n \rightarrow T_{p_i}L_i$ gives an embedding $SO(n)$ into the fiber of $P_{SO}(L_i)$ at p_i . We choose one of its lifts $\iota_i : Spin(n) \rightarrow P_{spin}(L_i)$ between two possible choices.

The trivialization σ of $\tilde{\lambda}_{l_0}$ also can be lifted, and we make a choice

$$(4.8) \quad \tilde{\sigma} : [0, 1] \times Spin(n) \cong P_{spin}(\lambda_{l_0}).$$

Now, we can use $\tilde{\sigma}, \iota_0, \iota_1$ to glue $P_{spin}(L_0), P_{spin}(\lambda_{l_0}), P_{spin}(L_1)$ at p_0 and p_1 . Namely, we glue $P_{spin}(L_i)$ and $P_{spin}(\lambda_{l_0})$, using $\iota_i \circ \tilde{\sigma}^{-1}$ at p_i for $i = 0, 1$.

We emphasize that with these pre-fixed data, we have the canonical spin structure of λ for the generator (w, l_p) : for $T_{w(\gamma(t))}L_0$ with $0 \leq t \leq \frac{1}{3}$, we have $P_{spin}(L_0)$ and for $T_{w(\gamma(t))}L_1$ with $\frac{2}{3} \leq t \leq 1$, we have $P_{spin}(L_1)$, and for $\lambda_{l_0}(t)$ for $\frac{1}{3} \leq t \leq \frac{2}{3}$, we have $P_{spin}(\lambda_{l_0})$. At $t = \frac{1}{3}$ (resp. $t = \frac{2}{3}$), we glue $P_{spin}(\lambda_{l_0})$ and $P_{spin}(L_0)$ (resp. $P_{spin}(L_1)$) by $\iota_0 \circ \tilde{\sigma}^{-1}$ (resp. $\iota_1 \circ \tilde{\sigma}^{-1}$).

Similarly, we can also construct a canonical spin structure on a loop C of paths from l_0 to itself.

4.3. Gluing theorems

We need to recall some elementary facts on determinant (index) spaces of CR operators. See [37, Section (11c)] for more explanations.

First, we consider the gluing of CR operators on Z_- and the one on holomorphic strips, and investigate the relation between orientation spaces before and after the gluing. Let S_1 be given by Z_- , and let S_2 be a strip $\mathbb{R} \times [0, 1]$. Consider a J -holomorphic strip connecting two intersection points p and q and the induced Lagrangian sub-bundle data λ' along $\partial S_2 = \mathbb{R} \times \{0, 1\}$, which give rise to a weighted CR operator $\bar{\partial}_{\lambda', S_2}$.

The standard gluing theorem for the weighted CR operators $\bar{\partial}_{\lambda, S_1}$ for S_1 , and $\bar{\partial}_{\lambda', S_2}$ for S_2 says that

$$(4.9) \quad \det(\bar{\partial}_{\lambda, S_1}) \otimes \det(\bar{\partial}_{\lambda', S_2}) \cong \det(\bar{\partial}_{\lambda \# \lambda', S_3}),$$

where $S_3 = Z_-$ and by $\lambda \# \lambda'$, we mean the Lagrangian sub-bundle data along ∂S_3 obtained by concatenating that of $\mathbb{R} \times \{1\} \subset \partial S_2$ backwards, that of S_1 , and that of $\mathbb{R} \times \{0\} \subset S_2$. (See (a) of Figure 3.)

Hence, the determinant line bundle $\det(\bar{\partial}_{\lambda', S_2})$ for the holomorphic strip is obtained as a tensor product (compare with (2.7))

$$\det(\bar{\partial}_{\lambda, S_1}) \otimes \det(\bar{\partial}_{\lambda \# \lambda', S_3}).$$

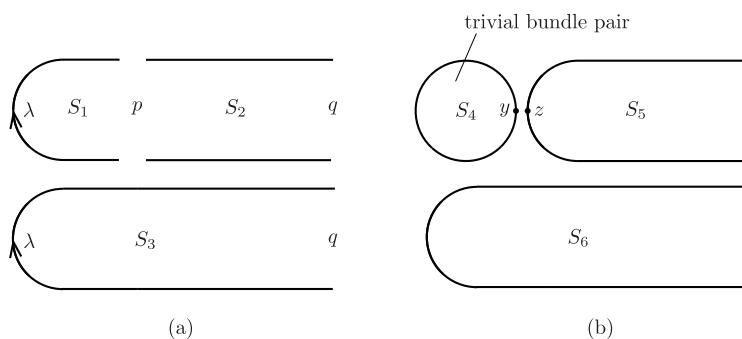

Figure 3: (a) Gluing of S_1 and S_2 (b) Gluing of S_4 and S_5 .

In the discussion below we need another type of gluing result. Let S_4 be a disc with a trivial symplectic bundle E_4 and a Lagrangian sub-bundle F_4 (which is not necessarily trivial) along ∂S_4 and consider $S_5 = Z_-$ and

a trivial symplectic bundle E_5 and a Lagrangian sub-bundle F_5 along ∂S_5 which is fixed sub-bundle for $\{z \in Z_- \mid \operatorname{Re}(z) \geq 0\}$ as in (4.2).

Consider boundary marked points $y \in \partial S_4$, and $z \in \partial S_5$ and an identification $E_{4,y} \cong E_{5,z}$ which identifies $F_{4,y}$ with $F_{5,z}$. Then determinant spaces of the associated CR operators satisfy

$$(4.10) \quad \det(\bar{\partial}_{S_4}) \otimes \det(\bar{\partial}_{S_5}) \cong \det(\bar{\partial}_{S_6}) \otimes \wedge^{\text{top}} F_{5,z},$$

where $S_6 = Z_-$ with a Lagrangian sub-bundle data along ∂S_6 obtained by concatenating that of $\mathbb{R} \times \{1\} \subset \partial S_5$ backwards, that of S_4 counter-clockwise, and that of $\mathbb{R} \times \{0\} \subset S_5$. (See (b) of Figure 3.) Here, the new term $\wedge^{\text{top}} F_{5,z}$ appears because the elements of the kernel of Cauchy-Riemann problem on S_4 and S_5 should have the same boundary value in $F_{4,y} = F_{5,z}$ at $y = z$.

Later, we will need the following lemma (due to Fukaya-Oh-Ohta-Ono (spin) and Seidel (pin)).

Lemma 4.4. [25, Theorem 8.1.1],[37, Lemma 11.17] *Let ρ be a loop in the Lagrangian Grassmannian. Then a choice of pin structure determines an isomorphism*

$$\det(\bar{\partial}_{D,\rho}) \cong \wedge^{\text{top}} \rho(0).$$

One way to interpret this lemma is to say that the choice of pin structure gives rise to a canonical orientation of the determinant space (relative to $\rho(0)$). This lemma will be used with (4.10) for a Lagrangian loop ρ of ∂S_4 so that we have a canonical isomorphism between $\det(\bar{\partial}_{S_5})$ and $\det(\bar{\partial}_{S_6})$.

Let us briefly review the argument in the case of a Maslov index zero loop. First consider ρ to be a constant loop. Then, it has a preferred spin structure (corresponding to the trivial extension to the disc), which we call a trivial spin structure. Then, the kernel is identified with $\rho(0)$ whereas the cokernel is trivial (see Proposition 8.1.4 [25]).

If it is equipped with a non-trivial spin structure, then we add the sign (-1) to this identification (see Theorem 6.4 [12] or Proposition 8.1.16 [25]).

Note that a constant loop along S^1 may admit a non-trivial extension (from $\pi_2(U(n)/O(n))$) to a disc D^2 , which induces a nontrivial spin structure. We thank the referee for pointing this out and the error in the original manuscript.

For a non-constant ρ of index zero, we consider a homotopy from ρ to a trivial loop. This homotopy provides a correspondence between spin structure of ρ and that of the trivial loop. Then, we can extend the identification $\det(\bar{\partial}_{D,\rho}) \cong \wedge^{\text{top}} \rho(0)$ accordingly.

4.4. Γ -equivalences and orientation spaces

We have defined the closed 1-form α (4.1) on $\Omega(L_0, L_1; l_0)$, and considered the Novikov covering $\tilde{\Omega}(L_0, L_1; l_0)$ by using Γ -equivalences on bounding surfaces of paths to define action functional \mathcal{A} .

We will use orientation spaces $\Theta_{(w, l_p)}^-$ (see Definition 4.3) as generators of the Floer complex instead of the Γ -equivalence class $[w, l_p]$ itself. Hence, we need to identify two orientation spaces $\Theta_{(w, l_p)}^-$ and $\Theta_{(w', l_p)}^-$ from Γ -equivalent representatives (w, l_p) and (w', l_p) .

For this, we have the following lemma, which is well-known and follows from Proposition 8.8.1 of [25].

Lemma 4.5. *Orientation spaces for different representatives of $[w, l_p]$ can be canonically identified, and we may denote it as $\Theta_{[w, l_p]}^-$ without ambiguity for each $[w, l_p] \in Cr(L_0, L_1; l_0)$.*

Proof. Pick two different representatives (w', l_p) and (w, l_p) in a Γ -equivalence class $[w, l_p]$. If we regard w and w' as paths in $\Omega(L_0, L_1; l_0)$, w' is homotopic to $w' \star \bar{w} \star w$. Thus, w' can be thought of as the concatenation of $w' \star \bar{w}$ and w . Let $\lambda_{w' \star \bar{w}}$ be the associated Lagrangian bundle data of $w' \star \bar{w}$ along the boundary. Note that by the definition of Γ -equivalences, $w' \star \bar{w}$ has energy zero, and $\mu(\lambda_{w' \star \bar{w}}) = 0$.

To relate $\Theta_{(w, l_p)}^-$ and $\Theta_{(w', l_p)}^-$, we consider gluing of $\bar{\partial}_{\lambda_{w' \star \bar{w}}, D^2}$ to $\bar{\partial}_{\lambda_w, Z_-}$ at a point. (See Figure 4.) Here, the domain of the $\bar{\partial}$ -operator associated with $\lambda_{w' \star \bar{w}}$ is replaced by D^2 (instead of a rectangle) to use gluing theorems in Subsection 4.3 more conveniently.

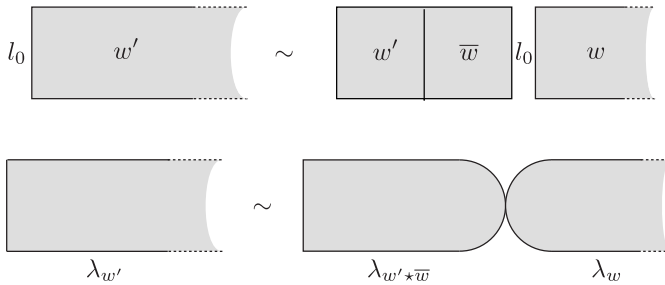

Figure 4: Gluing of $\bar{\partial}_{\lambda_{w' \star \bar{w}}, D^2}$ and $\bar{\partial}_{\lambda_w, Z_-}$.

The index formula (4.10) tells us that

$$(4.11) \quad \det(\bar{\partial}_{\lambda_w, Z_-}) \otimes \det(\bar{\partial}_{\lambda_{w' \star \bar{w}}, D^2}) \cong \det(\bar{\partial}_{\lambda_{w'}, Z_-}) \otimes \wedge^{top} \lambda_z$$

for some $z \in \partial Z_-$. From Lemma 4.4 (with the spin structure on $\lambda_{w' \star \bar{w}}$ chosen as in Subsection 4.2), we have an identification

$$(4.12) \quad \det(\bar{\partial}_{\lambda_{w' \star \bar{w}}, D^2}) \cong \wedge^{top} \lambda_z.$$

Combining (4.11) and (4.12), we get the canonical identification

$$\det(\bar{\partial}_{\lambda_w, Z_-}) \cong \det(\bar{\partial}_{\lambda_{w'}, Z_-}).$$

□

Sometimes, the Γ -equivalence is better understood in terms of attaching a cylinder to the bounding surface. Namely, we may consider a cylinder C (loop of paths based at l_0) so that $C \star w = w'$. Similar proof can be used to identify two orientation spaces in this sense also.

Now, naive generators of the Floer complex are the critical points of \mathcal{A} which are given by

$$(4.13) \quad Cr(L_0, L_1; l_0) = \left\{ [w, l_p] \in \tilde{\Omega}(L_0, L_1; l_0) \mid p \in L_0 \cap L_1 \right\},$$

where l_p is the constant path at p . If an element $c \in \Pi(L_0, L_1; l_0)$ is represented by the loop C of $\pi_1(\Omega(L_0, L_1; l_0))$, then the action of $\Pi(L_0, L_1; l_0)$ on $Cr(L_0, L_1; l_0)$ is defined by

$$c \cdot [w, l_p] = [C \star w, l_p].$$

From this action, one can naturally define a $R[\Pi(L_0, L_1; l_0)]$ -module which is generated by elements in $Cr(L_0, L_1; l_0)$. The actual definition of the cochain complex should also involve the orientation spaces associated to the generators in (4.13). More precisely, consider the formal sum

$$\mathfrak{r} = \sum_{\mu([w, l_p])=k} a_{[w, l_p]} x_{[w, l_p]}$$

where $a_{[w, l_p]} \in R$ and $x_{[w, l_p]} \in \left| \Theta_{[w, l_p]}^- \right|_R$.

Let

$$\text{supp}(\mathfrak{r}) := \{[w, l_p] \in Cr(L_0, L_1; l_0) \mid a_{[w, l_p]} \neq 0\}.$$

We call the sum \mathfrak{r} a Floer cochain of degree k if

$$\#(\text{supp}(\mathfrak{r} \cap \{[w, l_p] \mid \mathcal{A}([w, l_p]) \leq \lambda\})) < \infty$$

for any $\lambda \in \mathbb{R}$.

We denote the set of all Floer cochains of degree k by $CF_R^k(L_0, L_1; l_0)$ and we define

$$(4.14) \quad CF_{R, l_0}^*(L_0, L_1) := \bigoplus_k CF_R^k(L_0, L_1; l_0).$$

From the $\Pi(L_0, L_1; l_0)$ -action $Cr(L_0, L_1; l_0)$, we get a natural $\Lambda^R(L_0, L_1; l_0)$ -module structure of $CF_{R, l_0}^*(L_0, L_1)$.

5. Spin profiles

Consider G -invariant Lagrangian submanifolds and suppose further that they admit G -invariant spin structures. Although spin structures are G -invariant, group actions on the frame bundles of Lagrangians do not lift in general to the one on spin bundles. For example, consider a reflection $A \in O(n)$, and its lift $\tilde{A} \in Pin(n)$. Then, $A^2 = Id$, but we have $\tilde{A}^2 = (-1)^{r(r-1)/2} e$ where r is the rank of $Ker(Id + A)$ [37, Lemma 11.4]. Hence, the $\mathbb{Z}/2$ -action given by A on \mathbb{R}^n induces the action on $Pin(n)$ only up to signs, and the sign error indeed has an important geometric origin. For the general group actions, we will regard these sign differences as a group cohomology class, and call them spin profiles.

5.1. Spin structures and spin profiles

Before presenting the definition of spin profiles, we briefly recall basic facts on spin structures for reader's convenience.

Let $Cl(\mathbb{R}^n)$ be the Clifford algebra. There is a natural embedding $\mathbb{R}^n \rightarrow Cl(\mathbb{R}^n)$ and vectors satisfy the relation $v^2 = ||v||^2 e$ for the unit $e \in Cl(\mathbb{R}^n)$. Then, $Pin(n) \subset Cl(\mathbb{R}^n)^\times$ is defined as the multiplicative subgroup generated by $S^{n-1} \subset \mathbb{R}^n$, and $Spin(n) \subset Cl(\mathbb{R}^n)^\times$ the subgroup of $Pin(n)$ whose elements are given by products of even number of generators in S^{n-1} . Both of homomorphisms $Pin(n) \rightarrow O(n)$ and $Spin(n) \rightarrow SO(n)$ are induced by

the twisted adjoint action on \mathbb{R}^n , sending $w \mapsto -v w v$ for each generator $v \in S^{n-1}$.

A spin structure on L is a principal $Spin(n)$ bundle $\pi : P_{spin}(L) \rightarrow L$ which is a fiberwise double cover of the principal orthonormal frame bundle $\pi' : P_{SO}(L) \rightarrow L$. Let $pr : P_{spin}(L) \rightarrow P_{SO}(L)$ be the covering map such that $\pi = \pi' \circ pr$. $H^1(L; \mathbb{Z}/2)$ acts on the set of isomorphism classes of spin structures on L and the action is free and transitive. Thus, it is an affine space modeled on $H^1(L; \mathbb{Z}/2)$. In fact, Milnor [32] has shown that a spin structure of a vector bundle on a simplicial complex can be understood as a trivialization (or stable-trivialization if the rank of the bundle is less than 3) of the vector bundle on the 1-skeleton, which can be extended to the 2-skeleton. Then, the action of $H^1(L; \mathbb{Z}/2)$ can be interpreted as changing the trivialization of the vector bundle along the non-trivial loops in the 1-skeleton. For example, homotopy classes of trivializations of a rank n vector bundle on $[0, 1]$ (with fixed trivialization at the end points) could differ by a loop of $\pi_1(SO(n))$, but trivial and non-trivial loops have different lifts into $Spin(n)$.

We are particularly interested in the vector bundle on a circle. If the vector bundle $F \rightarrow S^1$ is spin, then there are two choices of spin structures. However, there is no preferred choice unless we know that the vector bundle F can be extended to $F' \rightarrow D^2$ with $\partial D^1 = S^1$. If F has extension, there is a unique spin structure on $F \rightarrow S^1$ which extends to $F' \rightarrow D^2$.

Let us first make the following necessary assumption.

Assumption 5.1. Let L be a connected spin (orientable) Lagrangian submanifold with a choice of spin structure and suppose the G -action on L is orientation preserving. We assume G preserves the isomorphism class of the given spin structure. i.e. a pulled-back spin structure by g is isomorphic to the original one for each $g \in G$. Such spin structures are said to be G -invariant.

Remark 5.2. We do not consider the case that spin structure is not G -invariant.

Remark 5.3. Recall that L is said to be relatively spin, if there exist a class $w \in H^2(M, \mathbb{Z}/2)$ such that the restriction of $(w + w_2(L))$ to L is zero, and hence there exist a bundle V on 3-skeleton of M , such that $(V \oplus TL)|_L$ becomes spin. Floer homology between two relatively spin Lagrangian submanifolds can be defined only if they become relatively spin with the same V .

With G -actions, we can work with $w \in H_G^2(M, \mathbb{Z}/2)$ so that there exist a G -bundle V on 3 skeleton of M with $(V \oplus TL)|_L$ being spin and G -invariant. We leave further details to the readers, and consider the case that L is spin from now on.

Given a G -action on L , let us denote by $A_g : L \rightarrow L$ its action $A_g(x) = g \cdot x$ for $g \in G$ and $x \in L$, and let a G -invariant metric be given on M . We denote the orthonormal frame bundle of L by $P_{SO}(L)$, which has an induced G -action denoted by $A_g^{SO} : P_{SO}(L) \rightarrow P_{SO}(L)$. In fact, A_g^{SO} provides an isomorphism

$$(5.1) \quad (A_{g^{-1}})^* P_{SO}(L) \rightarrow P_{SO}(L).$$

Let us fix a spin structure of L satisfying the above assumption 5.1. We would like to lift $A_g^{SO} : P_{SO}(L) \rightarrow P_{SO}(L)$ to a map A_g^{spin} between spin bundles

$$(5.2) \quad A_g^{spin} : P_{spin}(L) \rightarrow P_{spin}(L).$$

Such a lift exists by the assumption 5.1 and the standard covering theory argument. (5.2) Indeed, an explicit isomorphism of bundles over $P_{SO}(n)$

$$T_g : (A_{g^{-1}})^* P_{spin}(L) \xrightarrow{\cong} P_{spin}(L)$$

from (5.2) can be viewed as a lift of A_g^{SO} in (5.1). Note that the lift is not unique, as it can be multiplied by $(-1) \in Spin(n)$ to produce another one. We always choose the lift A_e^{spin} for the identity element $e \in G$ to be the identity map on $P_{spin}(L)$.

For $g, h \in G$, we have a natural map given by the composition

$$(5.3) \quad (A_{(gh)^{-1}})^* P_{spin}(L) = (A_{g^{-1}})^* (A_{h^{-1}})^* P_{spin}(L) \\ \xrightarrow{(A_{g^{-1}})^* T_h} (A_{g^{-1}})^* P_{spin}(L) \xrightarrow{T_g} P_{spin}(L).$$

But it does not necessarily equal T_{gh} , but possibly differs by multiplication of $\pm 1 \in Spin(n)$ if the group action on the frame bundle does not lift to the one on the spin bundle. Note that this difference ± 1 is locally constant function on $x \in L$.

Definition 5.4. The function $\text{spf}_L : G \times G \rightarrow \mathbb{Z}/2$ is defined implicitly by the relation

$$(5.4) \quad T_g \circ (A_{g^{-1}})^* T_h = (-1)^{\text{spf}_L(g,h)} T_{gh},$$

where ± 1 means the multiplication by $\pm 1 \in \text{Spin}(n)$.

If L has several connected components, we make the following assumption which enables us to get a constant spf_L , not depending on connected components. See (ii) of Subsection 5.3 below for more discussions on this issue.

Assumption 5.5. If L is not connected (but L/G is connected), then we assume that component-preserving subgroups of G are the same for every connected components of L and normal in G . We assume further that each connected component has the same spin profile with respect to the action of the component-preserving subgroup.

We will show that $\text{spf}_L : G \times G \rightarrow \mathbb{Z}/2$ defines an second group cohomology class which is independent of choices of T_g 's. Thus, for example, if we have an induced group action on spin bundles, spf_L is cohomologous to 0.

Proposition 5.6. spf_L defines group cohomology class in $H^2(G; \mathbb{Z}/2)$, which we call a spin profile of L . The function spf_L depends on the choices of the lifts $A_g^{\text{spin}}, \forall g \in G$, but the resulting group cohomology class $[\text{spf}_L]$ is independent of these choices.

Proof. We first show that spf_L is indeed a cocycle for the group cohomology $H^*(G, \mathbb{Z}/2)$.

Let G' be the set of all liftings of A_g^{SO} for every $g \in G$. Clearly, G' forms a group and the map $G' \rightarrow G$ sending $\pm A_g^{\text{spin}} \rightarrow g$ is 2 to 1. The kernel of $G' \rightarrow G$ consists of the liftings of the identity, which are $\pm 1 \in \text{spin}(n)$. Therefore we get the following exact sequence of groups

$$(5.5) \quad 0 \rightarrow \mathbb{Z}/2\mathbb{Z} \rightarrow G' \rightarrow G \rightarrow 1.$$

The choice of lifts $A_g^{\text{spin}} \in G'$ for each $g \in G$ defines a section $\sigma : G \rightarrow G'$ by setting $\sigma(g) = A_g^{\text{spin}}$, which may *not* be a group homomorphism. Recall that $\sigma(e) = A_e^{\text{spin}}$ is assumed to be the identity.

As $\mathbb{Z}/2\mathbb{Z}$ is abelian, it naturally admits a G -module structure by conjugation: for $h \in \mathbb{Z}/2\mathbb{Z}$ we write this conjugation action as $h^g = \sigma(g)h\sigma(g)^{-1}$,

which is independent of the choice of σ . From general theory of group extension, extensions G' as in (5.5) are classified by a cohomology class in $H^2(G, \mathbb{Z}/2\mathbb{Z})$ given by so called the factor set

$$[g, h] = \sigma(g)\sigma(h)\sigma(gh)^{-1}.$$

Since $[g, h] : P_{spin}(L) \rightarrow P_{spin}(L)$ covers the identity from $P_{SO}(L)$ to itself, it should be either $\pm 1 \in spin(n)$. Thus, the factor set is indeed a map

$$[,] : G \times G \rightarrow \mathbb{Z}/2\mathbb{Z}$$

which exactly agrees with spf_L in the definition 5.4.

The following lemma is standard, whose proof is omitted. (see [43, Section 6.6].)

Lemma 5.7. *We have*

- 1) $[g, e] = [e, g] = 0$ for all $g \in G$,
- 2) $[g, h]^f - [fg, h] + [f, gh] - [f, g] = 0$ for all $f, g, h \in G$.

Here, we used additive notation for $\mathbb{Z}/2\mathbb{Z}$ to emphasize that it is abelian.

From the lemma we get a cohomology class $[,]$ in $H^2(G; \mathbb{Z}/2\mathbb{Z})$. Now we show that the class does not depend on the choice of a section σ . Let σ' be another section (which is also regarded as a lifting of each g in G to an isomorphism $P_{spin}(L) \rightarrow P_{spin}(L)$ covering $g : L \rightarrow L$). Then, there exists $\beta : G \rightarrow \mathbb{Z}/2\mathbb{Z}$ such that

$$\sigma'(g) = \beta(g)\sigma(g)$$

for all $g \in G$. The factor set $[,]'$ corresponding to σ' is

$$\begin{aligned} [g, h]' &= \beta(g)\sigma(g)\beta(h)\sigma(h)\sigma(gh)^{-1}\beta(gh)^{-1} \\ &= \beta(g) + \sigma(g)\beta(h)\sigma(g)^{-1} + \sigma(g)\sigma(h)\sigma(gh)^{-1} + \beta(gh)^{-1} \\ &= [g, h] + \beta(h)^g - \beta(gh) + \beta(g). \end{aligned}$$

Therefore, $[,]$ and $[,]'$ are cohomologous and give the same cohomology class $[spf_L] \in H^2(G; \mathbb{Z}/2\mathbb{Z})$. □

5.2. Comparison of spf_L for two different spin structures on L

Once a G -invariant spin structure (satisfying assumption 5.1) is fixed, the spin profile of L is uniquely determined as seen in the previous subsection.

We now analyze the dependence of the spin profiles $[\text{spf}_L]$ on the choice of spin structures on L .

Proposition 5.8. *Let s and t be two G -invariant spin structures and denote the resulting spin profiles by $[\text{spf}_L^s]$ and $[\text{spf}_L^t]$, respectively. Then, there exists an exact sequence*

$$(5.6) \quad H^1(L; \mathbb{Z}/2\mathbb{Z})^G \rightarrow H^2(G; \mathbb{Z}/2\mathbb{Z}) \rightarrow H^2(\pi_1^{\text{orb}}[L/G]; \mathbb{Z}/2)$$

such that the first map sends the difference of two spin structures $s - t \in H^1(L; \mathbb{Z}/2\mathbb{Z})^G$ to the difference of two spin profiles $[\text{spf}_L^s] - [\text{spf}_L^t]$.

The proof will occupy the remainder of this subsections. We may assume that the frame bundle of L has rank greater than 2 via stabilization (taking a direct sum with a trivial bundle), so that π_1 of the fiber is $\mathbb{Z}/2\mathbb{Z}$. We can also extend the group action trivially. Orientation analysis of Lagrangian Floer theory can be modified suitably as in [25, p.681-682] since the orientation data from a trivial bundle pair has the canonical orientation.

If L is spin, the fibration $SO(n) \rightarrow P_{SO}(L) \rightarrow L$ induces the following short exact sequence

$$(5.7) \quad 1 \rightarrow \mathbb{Z}/2\mathbb{Z} \rightarrow \pi_1(P_{SO}(L)) \xrightarrow{p} \pi_1(L) \rightarrow 1.$$

The inclusion of the fiber induces the first injection $\pi_1(SO(n)) \rightarrow \pi_1(P_{SO}(L))$. One can check that this is in fact a central extension.

Let $s : \pi_1(L) \rightarrow \pi_1(P_{SO}(L))$ be a homomorphism, which is a section of p , i.e $p \circ s = id$.

Lemma 5.9. *A choice of spin structures on L is equivalent to a choice of a section s of the map p of (5.7).*

Proof. If we are given a spin structure $P_{spin}(L)$ on L , then from the diagram

$$\begin{array}{ccccccc} 1 & \longrightarrow & \pi_1(P_{spin}(L)) & \xrightarrow{q} & \pi_1(L) & \longrightarrow & 1 \\ & & \downarrow \pi & & \downarrow = & & \\ 1 & \longrightarrow & \mathbb{Z}/2\mathbb{Z} & \longrightarrow & \pi_1(P_{SO}(L)) & \xrightarrow{p} & \pi_1(L) \longrightarrow 1, \end{array}$$

$s := \pi \circ q^{-1}$ is a desired section. Note that $p \circ s = p \circ \pi \circ q^{-1} = q \circ q^{-1} = id$.

Conversely, suppose there exists a section $s : \pi_1(L) \rightarrow \pi_1(P_{SO}(L))$ of (5.7). Then, the image of s is an index 2 subgroup of $\pi_1(P_{SO}(L))$, which

determines a 2-fold covering of $P_{SO}(L)$. Denote this covering by $P_{spin}(L)$ and let F be a general fiber of $P_{spin}(L) \rightarrow L$.

$$\begin{array}{ccccccc}
 \pi_1(F) & \longrightarrow & \pi_1(P_{spin}(L)) & \xrightarrow{q} & \pi_1(L) & \longrightarrow & \pi_0(F) \\
 \downarrow & & \downarrow \pi & & \downarrow = & & \\
 1 & \longrightarrow & \mathbb{Z}/2\mathbb{Z} & \longrightarrow & \pi_1(P_{SO}(L)) & \xrightarrow{p} & \pi_1(L) \longrightarrow 1
 \end{array}$$

From the construction, q in the diagram above is an isomorphism and hence $\pi_1(F) = \pi_0(F) = 1$. Then, [42, Theorem 1.4] tells us that $P_{spin}(L)$ is indeed a spin structure on L . □

A choice of such a section geometrically means a choice of trivialization of TL along each based loop in $\pi_1(L)$. If $t : \pi_1(L) \rightarrow \pi_1(P_{SO}(L))$ is another section, then their difference $s - t$ is a group homomorphism from $\pi_1(L)$ to $\mathbb{Z}/2\mathbb{Z}$. i.e an element of

$$\text{Hom}(\pi_1(L), \mathbb{Z}/2\mathbb{Z}) = \text{Hom}(H_1(L), \mathbb{Z}/2\mathbb{Z}) = H^1(L; \mathbb{Z}/2\mathbb{Z}).$$

Now, the bundle $P_{SO}(L) \rightarrow L$ is G -equivariant, and hence we can consider an induced map of orbifold fundamental groups

$$p^{orb} : \pi_1^{orb}[P_{SO}(L)/G] \rightarrow \pi_1^{orb}[L/G].$$

Note that p^{orb} is surjective. Indeed given any path γ from x_0 to $g(x_0)$ for $g \in G$, $P_{SO}(L)|_\gamma$ is a trivial $SO(n)$ -bundle over γ . Thus, if \tilde{x}_0 is a base point in $P_{SO}(L)$ lying over x_0 , we can find a path from \tilde{x}_0 to $g\tilde{x}_0$ which covers γ .

The following lemma is straightforward.

Lemma 5.10. *We have the commutative diagram of group homomorphisms as below.*

$$\begin{array}{ccccccc}
 & & 1 & & 1 & & 1 \\
 & & \downarrow & & \downarrow & & \downarrow \\
 1 & \longrightarrow & \mathbb{Z}/2\mathbb{Z} & \longrightarrow & \mathbb{Z}/2\mathbb{Z} & \longrightarrow & 1 \longrightarrow 1 \\
 & & \downarrow & & \downarrow & & \downarrow \\
 1 & \longrightarrow & \pi_1(P_{SO}(L)) & \longrightarrow & \pi_1^{orb}[P_{SO}(L)/G] & \longrightarrow & G \longrightarrow 1 \\
 & & \downarrow \left. \begin{array}{l} p \\ \uparrow s \end{array} \right\} & & \downarrow p^{orb} & & \downarrow = \\
 1 & \longrightarrow & \pi_1(L) & \longrightarrow & \pi_1^{orb}[L/G] & \longrightarrow & G \longrightarrow 1 \\
 & & \downarrow & & \downarrow & & \downarrow \\
 & & 1 & & 1 & & 1
 \end{array}$$

Analogously to Lemma 5.9, we show that the splitting of the second column in the above diagram is equivalent to having a G -action on the spin bundle induced by the section s of (5.7). In other words, the obstruction to lift the G -action on $P_{SO}(L)$ to $P_{spin}(L)$ lies in the second group cohomology class determining the group extension in the second column.

Lemma 5.11. *Fix a spin structure on L which is induced by a section*

$$s : \pi_1(L) \rightarrow \pi_1(P_{SO}(L))$$

of (5.7). The G -action on L (and $P_{SO}(L)$) can be lifted to $P_{spin}(L)$ if and only if there exists a section s^{orb} of p^{orb} which fits into the following diagram.

$$\begin{array}{ccc}
 \pi_1(L) & \longrightarrow & \pi_1^{orb}[L/G] \\
 \downarrow s & & \downarrow s^{orb} \\
 \pi_1(P_{SO}(L)) & \longrightarrow & \pi_1^{orb}[P_{SO}(L)/G]
 \end{array}$$

where horizontal maps come from natural exact sequences

$$1 \rightarrow \pi_1(L) \rightarrow \pi_1^{orb}[L/G] \rightarrow G \rightarrow 1$$

and

$$1 \rightarrow \pi_1(P_{SO}(L)) \rightarrow \pi_1^{orb}[P_{SO}(L)/G] \rightarrow G \rightarrow 1.$$

Proof. Firstly, suppose there is a section s^{orb} . We consider the universal cover Ω of $P_{SO}(L)$ which also can be regarded as a covering of $[P_{SO}(L)/G]$. Since Ω is simply connected, it is the orbifold universal cover of $[P_{SO}(L)/G]$ and hence $\pi_1^{orb}[P_{SO}(L)/G]$ acts on it. $\pi_1^{orb}[L/G]$ and its subgroup $\pi_1(L)$ also act on Ω via s^{orb} ($\pi_1^{orb}[L/G] \leq \pi_1^{orb}[P_{SO}(L)/G]$) and $s^{orb}(\pi_1(L)) = s(\pi_1(L)) \leq \pi_1^{orb}[P_{SO}(L)/G]$. We take the quotient of Ω by $\pi_1(L)$ -action so that the resulting quotient space is exactly the spin bundle $P_{spin}(L)$ associated to s . Then, clearly $\pi_1^{orb}[L/G]/\pi_1(L) \cong G$ acts on $P_{spin}(L)$.

On the other hand, if we have a G -action on $P_{spin}(L)$ which makes $P_{spin}(L) \rightarrow L$ and $P_{spin}(L) \rightarrow P_{SO}(L)$ G -equivariant, then we get a group homomorphism $\pi_1^{orb}[P_{spin}(L)/G] \rightarrow \pi_1^{orb}[L/G]$ and $\pi_1^{orb}[P_{spin}(L)/G] \rightarrow \pi_1^{orb}[P_{SO}(L)/G]$. The first map should be an isomorphism since the only element possibly contained in the kernel is a loop in the fiber and the fiber is simply connected. Thus,

$$(5.8) \quad \begin{array}{ccc} \pi_1^{orb}[L/G] & \xrightarrow{\quad\quad\quad} & \pi_1^{orb}[P_{SO}(L)/G] \\ & \searrow \cong & \nearrow \\ & \pi_1^{orb}[P_{spin}(L)/G] & \end{array}$$

gives a desired section. □

To prove Proposition 5.8, we need a slightly different commutative diagram, which is obtained from the above. The following lemma is given for this purpose, whose proof is elementary and omitted.

Lemma 5.12. *Let $s(\pi_1(L))$ be the image of the composition of inclusions $\pi_1(L) \xrightarrow{s} \pi_1(P_{SO}L) \rightarrow \pi_1^{orb}[P_{SO}(L)/G]$. If the section s corresponds to the G -invariant spin structure on L (see Lemma 5.9), then $s(\pi_1(L))$ is a normal subgroup of $\pi_1^{orb}[P_{SO}(L)/G]$.*

Consider the central column of the diagram in Lemma 5.10, and divide the 2nd and the 3rd rows by $s(\pi_1(L))$ and $\pi_1(L)$ respectively to obtain the following diagram

$$\begin{array}{ccccccc}
 (5.9) & & & & & & \\
 & & 1 & & 1 & & 1 \\
 & & \downarrow & & \downarrow & & \downarrow \\
 1 & \longrightarrow & 1 & \longrightarrow & \mathbb{Z}/2\mathbb{Z} & \longrightarrow & \mathbb{Z}/2\mathbb{Z} \longrightarrow 1 \\
 & & \downarrow & & \downarrow & & \downarrow \\
 1 & \longrightarrow & s(\pi_1(L)) & \longrightarrow & \pi_1^{orb}[PSO(L)/G] & \longrightarrow & G'_s \longrightarrow 1 \\
 & & \cong \downarrow & & p^{orb} \downarrow & & \downarrow \\
 1 & \longrightarrow & \pi_1(L) & \longrightarrow & \pi_1^{orb}[L/G] & \longrightarrow & G \longrightarrow 1 \\
 & & \downarrow & & \downarrow & & \downarrow \\
 & & 1 & & 1 & & 1
 \end{array}$$

Note that the 2nd column is independent of the choice of spin structure s . However, the 3rd column depends on the choice of $s(\pi_1(L))$, and only makes sense if s is a G -invariant spin structure (so that $s(\pi_1(L))$ is a normal subgroup).

Recall that the obstruction to lift G -action to the spin bundle lies in the existence of a section of p^{orb} . The bottom left square diagram of (5.9) shows that such a section exists at least on the subgroup $\pi_1(L)$ of $\pi_1^{orb}[L/G]$. Therefore, the obstruction descends to a group extension in the last column. (See [43, (Ex 6.6.4)].) Therefore, the extension of G in the last column gives rise to the second cohomology class $[\text{spf}_L^s] \in H^2(G, \mathbb{Z}/2)$, the spin profile of the spin bundle determined by s . For a different G -invariant spin structure $t : \pi_1(L) \rightarrow \pi_1(PSO(L))$, we get a similar diagram for the extension G'_t , and a possibly different spin profile $[\text{spf}_L^t] \in H^2(G, \mathbb{Z}/2)$.

Remark 5.13. The discussion in the first paragraph of the proof of Lemma (5.11) shows that G'_s genuinely acts on $P_{spin}(L)$, but its quotient G may not.

We recall from [43, (Ex 6.6.4)] that from the 2nd and the 3rd columns of the diagram (5.9) canonically induce a homomorphism $H^2(G; \mathbb{Z}/2\mathbb{Z}) \rightarrow H^2(\pi_1^{orb}[L/G]; \mathbb{Z}/2)$ which sends the cohomology class of the extension of the 3rd column to the one of the 2nd column. It implies that the cohomology class $[\text{spf}_L^s]$ maps to the extension class of the 2nd column in $H^2(\pi_1^{orb}[L/G]; \mathbb{Z}/2)$ under this induced homomorphism. But, the image of $[\text{spf}_L^s]$ is independent of the choice of spin structure s . This proves that the image of $[\text{spf}_L^s]$ and $[\text{spf}_L^t]$ coincide under this homomorphism.

From [43, (6.8.3)], we have the following exact sequence called *Lyndon-Hochschild-Serre spectral sequence* from the 3rd row of the diagram (5.9):

$$(5.10) \quad \begin{aligned} H^1(L; \mathbb{Z}/2\mathbb{Z})^G = H^1(\pi_1(L); \mathbb{Z}/2\mathbb{Z})^G &\rightarrow H^2(G; \mathbb{Z}/2\mathbb{Z}) \\ &\rightarrow H^2(\pi_1^{orb}[L/G]; \mathbb{Z}/2). \end{aligned}$$

Therefore, the difference of two spin profiles $[\text{spf}_L^s] - [\text{spf}_L^t]$ which maps to zero under the last homomorphism, is in the image of $H^1(L; \mathbb{Z}/2\mathbb{Z})^G$. As both s and t are G -invariant spin structures, the difference of two spin structures $s - t$ lies in $H^1(L; \mathbb{Z}/2\mathbb{Z})^G$. The first map in (5.10) sends it to the difference of two spin profiles $[\text{spf}_L^s] - [\text{spf}_L^t]$. This proves the proposition 5.8.

In addition, we explain how $s - t$ associates spf_L^s and spf_L^t in a more geometric way. For each $g \in G$, choose a path γ_g from x_0 to $g(x_0)$ and a trivialization of $TL|_{\gamma_g}$ i.e. an orthonormal frame of TL along γ_g . Then, the frame gives a path connecting \widetilde{x}_0 and $g(\widetilde{x}_0)$ in $PSO(L)$. The composition

$$l_{g,h} := h(\gamma_g) \star \gamma_h \star \overline{\gamma_{gh}} \in \pi_1(L)$$

(representing the element $[\gamma_g][\gamma_h][\gamma_{gh}]^{-1}$ in $\pi_1^{orb}[PSO(L)/G]$) is a loop based at x_0 on which a trivialization of TL is fixed. If this trivialization agrees with $t(l_{g,h})$, then we define $[g, h]_t = 1$ and $[g, h]_t = 0$ otherwise. $[\ , \]_t$ is exactly the factor set representing t in the cohomology. Now, it is not difficult to check that the factor set corresponding to s is given by

$$[g, h]_s = (s - t)(l_{g,h}) + [g, h]_t$$

where $(s - t)(l_{g,h})$ is the evaluation of an 1-cocycle $s - t \in H^1(L; \mathbb{Z}/2\mathbb{Z})$ at $l_{g,h}$.

5.3. Generalizations

(i) We finish the section with a short discussion on orientation reversing actions. Suppose that L is oriented, and a half of G -action on L is orientation reversing. Then, $(A_g)^*TL$ has opposite orientation compared to TL for an orientation reversing g .

We recall from [30] the following well-known fact on the correspondence of spin structures on an oriented vector bundle and spin structures on the vector bundle with the reversed orientation. Let $F \rightarrow B$ be an oriented vector bundle with transition functions g_{ij} on a cover $\{U_i\}_{i \in I}$ of B . Choose maps $h_i : U_i \rightarrow O(n) \setminus SO(n)$, and define the new transition maps

by $h_i \circ g_{ij} \circ h_j^{-1}$. Then a new vector bundle F^{op} is obtained which is isomorphic to F via the maps h_i . (This is not an isomorphism between oriented bundles.) Different choices of h_i yield isomorphic bundles. Similarly, by choosing $h_i : U_i \rightarrow Pin(n) \setminus Spin(n)$, we can find an isomorphism from spin structures $P_{spin}(F)$ to $P_{spin}(F^{op})$. This provides an isomorphism between sets of spin structures of F and F^{op} .

Back to our case, consider an oriented Lagrangian submanifold L and its spin structure $P_{spin}(L)$.

Assumption 5.14. We require that the spin structure $(A_g)^*P_{spin}(L)$ (of L^{op}) is isomorphic to the given spin structure $P_{spin}(L)$ (of L) for each orientation reversing $g \in L$ in the sense described above.

For each g , we choose an isomorphism

$$T_g : (A_{g^{-1}})^*(P_{spin}L) \rightarrow P_{spin}L.$$

Then, the spin profile of L is defined by (5.4) as well.

Remark 5.15. Seidel [37] used an isomorphism between pin structures

$$(A_g)^*(P_{pin}L \otimes \wedge^{top}TL) \cong P_{pin}L.$$

The additional factor $\wedge^{top}TL$ is not necessary for us since we only deal with orientable Lagrangian submanifolds here and hence $\wedge^{top}TL$ is a trivial bundle.

(ii) Here, we explain more details on spin profiles when L is not connected (but a G -orbit). In such a case, we have made Assumption 5.5.

As observed before, spf_L is a locally constant function, but not necessarily a constant function when L is not connected, since signs in (5.4) may also depend on connected components of L . We do not know how to handle the general case, but we add more arguments under the Assumption 5.5 together with 5.16 below. First of all, from Assumption 5.5 there exists a normal subgroup G_0 of G such that it preserves each connected component of L , and G/G_0 parametrizes the set of components.

Assumption 5.16. The following exact sequence splits

$$1 \rightarrow G_0 \rightarrow G \rightarrow G/G_0 \rightarrow 1.$$

For the rest of the paper, we will only deal with disconnected Lagrangian submanifolds satisfying the above assumption also. So, one can express G as a semi-direct product $G_1 \ltimes G_0$ where $G_1 \cong G/G_0$. For later use, let $\phi : G_1 \rightarrow \text{Aut}(G_0)$ determine the semi-direct product $G_1 \ltimes G_0$. The main advantage here is that the quotient group G/G_0 also can be viewed as a subgroup of G and hence, acts on L purely by permuting connected components. In particular, we can label connected components of L by $G_1 (\cong G/G_0) \leq G$.

We fix a G_0 -invariant spin structure on the connected component C_0 corresponding to $1 \in G_1$, and pull it back to the component C_α corresponding to $\alpha (\in G_1)$ by α^{-1} . As before we take a lift of G_0 -action on the spin bundle on C_0 which gives rise to a spin profile $\text{spf}_0 \in H^2(G_0; \mathbb{Z}/2)$. Likewise, we get a spin profile $\text{spf}_\alpha \in H^2(G_0; \mathbb{Z}/2)$ for each connected component C_α associated to $\alpha = (a, 1) \in G_1 (\leq G)$. Assumption 5.5 implies that $\text{spf}_\alpha = \text{spf}_0$ for all $\alpha \in G_1$.

For $g = (g_1, g_0) \in G = G_1 \ltimes G_0$ and $x = \alpha x_0 \in C_\alpha$, note that the connected component containing $g \cdot x$ is labeled by $(g_1 a, 1)$. So, $P_{\text{spin}}(L)_x = P_{\text{spin}}(L)_{x_0}$ and $P_{\text{spin}}(L)_{g \cdot x} = P_{\text{spin}}(L)_{(a^{-1} g_1^{-1}, 1)(g_1, g_0) \cdot x} = P_{\text{spin}}(L)_{(1, \phi_a(g_0)) \cdot x_0}$. Now we define a map $P_{\text{spin}}(L)_x \rightarrow P_{\text{spin}}(L)_{g \cdot x}$ by the following diagram:

$$\begin{array}{ccc} P_{\text{spin}}(L)_x & \longrightarrow & P_{\text{spin}}(L)_{g \cdot x} \\ \parallel & & \parallel \\ P_{\text{spin}}(L)_{x_0} & \longrightarrow & P_{\text{spin}}(L)_{\phi_a(g_0) \cdot x_0} \end{array}$$

where we abbreviate $(1, \phi_a(g_0)) \cdot x_0$ to $\phi_a(g_0) \cdot x_0 (\in C_0)$ to emphasize that the second row only depends on the choice of lift of G_0 -action to the spin bundle on C_0 .

Proposition 5.17. *Under Assumption 5.5, the above choice of lifts produces spf_L which does not depend on connected components of L .*

Proof. The condition $\text{spf}_\alpha = \text{spf}_0$ implies that spf_0 is invariant under the conjugation action of α on G_0 . The rest of the proof follows easily by the direct computation and is omitted. □

Analyzing component-preserving subgroups is subtle in general since this involves a study of conjugacy relation among subgroups in G . For example, two component-preserving subgroups G_1 and G_2 are always conjugate to each other, but possibly conjugated by more than one element in G . We have only dealt with the case when G can be decomposed nicely into “component

preserving” and “permuting” subgroup so that there is no complicated issue on conjugacy classes. We postpone more general discussion to [14].

6. Equivariant Fukaya categories for exact symplectic manifolds

The Floer action functionals are single-valued for exact symplectic manifolds, and hence Novikov theory is not needed in such cases. Equivariant Fukaya categories can be constructed in a relatively simple way (than the general case), and in fact this only requires a choice of a group cohomology class in $H^2(G, \mathbb{Z}/2)$. We remark that Seidel defined equivariant Fukaya category for $G = \mathbb{Z}/2$, and it corresponds to the non-trivial group cohomology class $H^2(\mathbb{Z}/2, \mathbb{Z}/2)$ in our language.

In this section, definitions of equivariant Lagrangian branes and equivariant Fukaya categories for exact symplectic manifolds will be provided. We will use notations and constructions by Seidel in [37] to which we refer readers for more details. At the end, we consider G -invariant parts of morphisms in these categories, which defines orbifolded Fukaya categories (or, its first approximation as we should add the theory of bulk deformation by twisted sectors).

Let (M, ω) be an exact symplectic manifold with an action of a finite group G . Suppose that we have a G -invariant quadratic volume form η^2 on M , and a G -invariant almost complex structure J_M . Let $\alpha_M : Gr(TM) \rightarrow S^1$ be a square phase map of η defined by $\eta(v_1 \wedge \cdots \wedge v_n)^2 / |\eta(v_1 \wedge \cdots \wedge v_n)|^2$ for any basis of V in the Lagrangian Grassmannian $Gr(TM)$.

A Lagrangian brane in the sense of [37] is a triple

$$L^\sharp = (L, \alpha^\sharp, P^\sharp),$$

where L is an exact Lagrangian submanifold with a grading $\alpha^\sharp : L \rightarrow \mathbb{R}$ satisfying $\alpha_M(T_x L) = \exp(2\pi i \alpha^\sharp)$ and a pin structure P^\sharp on it. For simplicity, we assume that L is oriented, and P^\sharp is a spin structure on L .

Let s be a group cohomology class $H^2(G, \mathbb{Z}/2)$.

Definition 6.1. A triple $(L, \alpha^\sharp, P^\sharp)$ is called an s -equivariant brane if

- 1) L is preserved by the G -action on M ;
- 2) α^\sharp is G -invariant;
- 3) The isomorphism class of P^\sharp is G -invariant and has a spin profile s .

We review each condition. If L is not preserved by G -action, then one can consider its equivariant family $\cup g \cdot L$ as an equivariant immersion from $|G|$ -copies of L to M . For simplicity, we require that each intersection $g(L) \cap L$ is either empty or equal to L for all $g \in G$.

Condition on G -grading can be met as follows. If L is connected, then $\alpha^\sharp \circ g - \alpha^\sharp$ is a locally constant function. Thus, $\alpha^\sharp \circ g - \alpha^\sharp = c$ on L , but since $g^{|g|} = 1$ we have $c = 0$. That is, α is automatically G -invariant. If L has several connected components, we first fix a grading on one component which is invariant under the action of the subgroup preserving the given component, and then define the gradings on other components by the group action.

As revealed before, a spin structure P^\sharp has an associated spin profile. If it is not equal to s , one may try to change P^\sharp to another spin structure and match the associated spin profile with s making use of the Proposition 5.8. However, it is not possible in general and (3) is, in fact, a critical condition.

The setup of Floer cochain complexes in [37] briefly goes as follows. Let (L_0^\sharp, L_1^\sharp) be two exact Lagrangian branes such that L_0 and L_1 intersect transversely at $y \in L_0 \cap L_1$. (In fact, transversal intersection conditions are not necessary as we are able to choose perturbation data (H_{01}, J_{01}) instead. We return to this point in a moment.) Then, the pair of linear Lagrangian branes $(k = 0, 1)$ at y is given by

$$\Lambda_{k,y}^\sharp = (\Lambda_{k,y} = (TL_k)_y, \alpha_{k,y}^\sharp = \alpha_k^\sharp(y), P_{k,y}^\sharp = (P_k^\sharp)_y).$$

Their index and orientation space are defined as in [37, (11.25)] and denoted by

$$i(y) = i(\Lambda_{0,y}^\sharp, \Lambda_{1,y}^\sharp), \quad o(y) = o(\Lambda_{0,y}^\sharp, \Lambda_{1,y}^\sharp).$$

Given a regular Floer datum, the graded Floer cochain group is defined as

$$CF^k(L_0^\sharp, L_1^\sharp) = \bigoplus_{o(y)=k} |o(y)|_R.$$

(See [37, (12.16)].)

Remark 6.2. If one changes the Pin structure P_k^\sharp by multiplying $(-1)^{\epsilon_k} e$ for $k = 0, 1$, then the resulting Pin structure is isomorphic to the original one, but the orientation space $o(y)$ is altered by the multiplication of $(-1)^{\epsilon_1 + \epsilon_2}$.

A Floer datum in [37] for a pair of objects (L_0, L_1) consists of

$$H_{01} \in C^\infty([0, 1], C_c^\infty(M, \mathbb{R})), \quad J_{01} \in C^\infty([0, 1], \mathcal{J}),$$

where \mathcal{J} is the space of compatible almost complex structures on M . They are required to satisfy that $\phi^1(L_0)$ is transverse to L_1 where ϕ^1 is the time one map of the Hamiltonian vector field of H_{01} . Given $g \in G$, one can push forward the Floer datum to get $g(H_{01}), g(J_{01})$ in an obvious way

We are now ready to define s -equivariant Fukaya categories (modifying the construction of Fukaya categories by Seidel).

Definition-Theorem 6.3. Let (M, ω) be an exact symplectic manifolds. For $s \in H^2(G, \mathbb{Z}/2)$, we define the s -equivariant Fukaya category as follows. Objects of the s -equivariant Fukaya category are s -equivariant branes. A morphism between two s -equivariant branes L_0^\sharp and L_1^\sharp is given by $CF^*(L_0^\sharp, L_1^\sharp)$, on which G acts linearly.

There exist A_∞ -operations

$$m_k : CF^*(L_0^\sharp, L_1^\sharp) \times \cdots \times CF^*(L_{k-1}^\sharp, L_k^\sharp) \rightarrow CF^*(L_0^\sharp, L_k^\sharp), \quad k = 1, 2, \dots$$

which are compatible with the G -action. i.e. for $k = 1, 2, \dots$

$$(6.1) \quad m_k(gx_1, \dots, gx_k) = gm_k(x_1, \dots, x_k).$$

Remark 6.4. The definition above should include a G -equivariant flat vector bundle for each s -equivariant brane, but we omit it for simplicity and postpone it to Section 12.

On the technical level, we should be able to handle the problem of equivariant transversality involved in the A_∞ -operations on Fukaya categories. Assuming transversality for a moment, we show that G -actions on morphisms can be defined canonically if both Lagrangian branes L_0^\sharp and L_1^\sharp have the same spin profile $[\text{spf}_{L_0}] = [\text{spf}_{L_1}] = s \in H^2(G; \mathbb{Z}/2)$. Then one can modify one of spf_{L_i} 's to have the strict identity $\text{spf}_{L_0} = \text{spf}_{L_1}$ by changing the lifts A_g^{spin} 's appropriately. For simplicity, we assume that this is the case from now on.

Assumption 6.5. We assume that

$$\text{spf}_{L_0} = \text{spf}_{L_1}.$$

We emphasize that this condition is necessary to define a group action on the Floer complex.

Lemma 6.6. *Consider two s -equivariant branes (L_0^\sharp, L_1^\sharp) . Suppose there exists a G -invariant regular Floer datum for these branes. Then, there exists a natural G -action on the Floer cochain group $\bigoplus_{o(y)=k} |o(y)|_R$.*

Proof. The equivariance of perturbation data implies that for each $g \in G$, the pulled-back of each equivariant brane L_i^\sharp under the g -action is isomorphic to L_i^\sharp itself for $i = 0, 1$. Hence, it is easy to see that for the intersections $y \in L_0 \cap L_1$ and $y' := g(y) \in g(L_0) \cap g(L_1) = L_0 \cap L_1$,

$$i(y) = i(y'), \quad o(y) \cong o(y').$$

The precise isomorphism on determinant lines $o(y) \cong o(y')$ has to be considered carefully. Recall that determinant line is defined from a Lagrangian path λ from $T_y L_0$ to $T_y L_1$ (from the grading of each Lagrangian) whose spin structure is determined from the spin structure of each Lagrangian. Since grading is G -invariant, g -action image of the Lagrangian path λ for $o(y)$ can be used to define $o(y')$. Here $g(\lambda)$ has an induced canonical spin structure from L_0 and L_1 (not from the g -action). This defines an isomorphism

$$o_g : o(y) \rightarrow o(y').$$

But the (canonical) spin structure for $o(y')$ from L_0 and L_1 at y' can be compared to the spin structure of $o(y)$ via group action, from the choice of a lift $T_{g,L_i} : (A_{g^{-1}})^* P_i \rightarrow P_i$ for each g ($i = 0, 1$). Since the lifts T_{g,L_i} for $g \in G$ do not define a group action due to sign error (5.4), the maps $\{g \mapsto o_g \mid g \in G\}$ do not define a group action on $\bigoplus_{o(y)=k} |o(y)|_R$, either. Instead, we have

$$o_g \circ o_h = (-1)^{\text{spf}_{L_0}(g,h) + \text{spf}_{L_1}(g,h)} o_{gh}.$$

However, both L_0, L_1 have the same spin profile $s = \text{spf}_{L_0} = \text{spf}_{L_1}$ by the definition of s -equivariant branes. Hence, the sign error cancels out and the maps $\{g \mapsto o_g \mid g \in G\}$ define a G -action on the Floer cochain group. \square

In what follows, we shall describe how to take care of equivariant transversality issue. Indeed, one can adapt the following algebraic technique introduced by Seidel in the exact case.

Lemma 6.7. *[38, Lemma 4.3] Let \mathcal{D} be an A_∞ -category with an action of a finite group G , and $D = H(\mathcal{D})$, the associated cohomology level category.*

Suppose that we have another graded linear category C with a G -action, and an equivalence $F : D \rightarrow C$, which is G -equivariant. Then, there is an A_∞ -category \mathcal{C} with $H(\mathcal{C})$ isomorphic to C , which carries an action of G , and an equivariant A_∞ -functor $\mathcal{F} : \mathcal{D} \rightarrow \mathcal{C}$ such that $H(\mathcal{F}) = F$.

Seidel observed that one can make G act freely on the set of objects of \mathcal{D} via introducing additional labels to objects in \mathcal{C} with elements of a group G (possibly making several copies of the same object). Now, it is much easier for \mathcal{D} to become G -equivariant. Then, the homological perturbation type lemma above is applied to obtain an equivariant A_∞ -structure on the category \mathcal{C} .

Let us spell out how to use this lemma to construct the A_∞ -operations in the s -equivariant Fukaya category without a transversality assumption. First, we define the A_∞ -category \mathcal{D} and a free G -action on it.

Definition 6.8. An object of \mathcal{D} is given by (L^\sharp, g) for $g \in G$. Here, $L^\sharp = (L, \alpha^\sharp, P^\sharp)$ is an s -equivariant brane of M and (L^\sharp, g) denotes an s -equivariant brane given by $(L, \alpha^\sharp, (g^{-1})^*P^\sharp)$. (L and α^\sharp are G -invariant as usual.) A morphism between (L_0^\sharp, g) and (L_1^\sharp, h) is

$$CF^*((L_0^\sharp, g), (L_1^\sharp, h)).$$

We fix the perturbation datum $(H_{01,g}, J_{01,g})$ of $((L_0^\sharp, 1), (L_1^\sharp, g))$ for each $g \in G$ and use the push forward datum $(g(H_{01,g^{-1}h}), g(J_{01,g^{-1}h}))$ for an arbitrary pair $((L_0^\sharp, g), (L_1^\sharp, h))$

A_∞ -operations on \mathcal{D} are defined in a standard way with aid of similarly chosen perturbation data for higher operations [37].

Lemma 6.9. A_∞ -category \mathcal{D} admits an action of G .

Proof. On the object level, $g \in G$ sends (L^\sharp, h) to (L^\sharp, gh) . The G -action on the set of objects is obviously free due to the additional index h in (L^\sharp, h) . Now we clarify how G acts on the morphism spaces. For simplicity, let us look at the following g -action

$$CF((L^\sharp, 1), (L^\sharp, h)) \rightarrow CF((L^\sharp, g), (L^\sharp, gh))$$

and other cases can be dealt in the same way.

Let $L_0 \cap L_1$ transversally intersect at y and denote $g(y) \in g(L_0) \cap g(L_1) = L_0 \cap L_1$ by y' . Then, we have $i(y) = i(y')$ from the G -invariant

gradings. Then, the group action $o_g : o(y) \rightarrow o(y')$ is defined in an obvious way. Recall that perturbation data for the left and the right hand sides are $(H_{01,h}, J_{01,h})$ and $(g(H_{01,h}), g(J_{01,h}))$ respectively. Moreover since the spin structure for the brane (L^\sharp, k) is defined as the pulled-back one via k , the g -action is compatible with A_∞ -operations. Therefore, the map $g \mapsto o_g$ defines a group action on \mathcal{D} . No ambiguity arises since g always sends an object to another. \square

Remark 6.10. We do not have to identify $(g^{-1})^*P^\sharp$ and P^\sharp for \mathcal{D} as they are now spin structures for different objects $(L^\sharp, 1)$ and (L^\sharp, g) in \mathcal{D} . Thus, \mathcal{D} can actually be enlarged to include equivariant branes with various spin profiles.

According to Lemma 6.7, it suffices to define a graded linear category C with a G -action and a G -equivariant equivalence $F : D \rightarrow C$ in order to define the s -equivariant Fukaya category. The graded linear category C is a refined version of Donaldson-Fukaya category in the sense that objects are given with gradings and pin structures.

Definition 6.11. Fix $s \in H^2(G, \mathbb{Z}/2)$. The linear category C is defined as follows. Objects of C are s -equivariant branes L^\sharp 's. A morphism between L_0^\sharp and L_1^\sharp is given by $HF^*(L_0^\sharp, L_1^\sharp)$. The composition of morphisms is defined by the triangle product as usual.

Note that morphisms are given by the Floer cohomology groups, rather than Floer cochain complexes. Our next task is to endow C with a group action. We carry out the construction of a group action on C , making use of the idea of weak group actions on chain complexes. It is employed in [13] to deal with the Morse complex of a non-invariant function on a global quotient and we, in fact, proved that the weak group action induces a strict group action on the Morse homology. Here, we need a slight generalization since the product structure is also required to be compatible with the G -action at least in a weak sense.

Lemma 6.12. *There exist a G -action on the linear category C and a G -equivariant functor $D \rightarrow C$, where D is the cohomology level category of \mathcal{D} .*

Proof. The sign issue arising from spin profiles can be handled as in Lemma 6.6, so we will discuss the question on perturbation data only.

Recall that the well-definedness of Donaldson-Fukaya category uses the following canonical isomorphisms. Let $(H_{01}, J_{01}), (H'_{01}, J'_{01})$ be two perturbation data for a pair (L_0^\sharp, L_1^\sharp) . From now on, we omit J -terms for notational simplicity. An one parameter family H_{01}^c connecting two such data gives rise to a continuation map $\Phi_{H_{01}^c}$ from the Lagrangian Floer complex for H_{01} to that for H'_{01} , which induces a canonical isomorphism between Floer cohomology groups $HF^*(L_0^\sharp, L_1^\sharp; H_{01})$ and $HF^*(L_0^\sharp, L_1^\sharp; H'_{01})$.

Given three perturbation data H_{01}, H'_{01} and H''_{01} , the continuation map from H_{01} to H''_{01} is homotopic to the composition of two continuation maps, one from H_{01} to H'_{01} and the other from H'_{01} to H''_{01} . This implies that the canonical isomorphisms on cohomology groups are compatible with compositions.

We consider a naive G -action on Floer complex which is a chain map, and compose it with the continuation map $\Phi_{H_{01}^g}$ from some family H_{01}^g from $g(H_{01})$ to H_{01} :

$$\Psi_g : CF^*(L_0^\sharp, L_1^\sharp; H_{01}) \xrightarrow{g} CF^*(L_0^\sharp, L_1^\sharp; g(H_{01})) \xrightarrow{\Phi_{H_{01}^g}} CF^*(L_0^\sharp, L_1^\sharp; H_{01}).$$

Then, Ψ_g is clearly a chain map, and we claim that it defines a weak action on the chain complex $CF^*(L_0^\sharp, L_1^\sharp; H_{01})$, in the following sense:

$$(6.2) \quad \Psi_g \circ \Psi_h - \Psi_{gh} = \sigma_{g,h} \circ m_1 + m_1 \circ \sigma_{g,h}.$$

The proof of the claim goes as follows. First, one can check that the family $H_{01}^g \circ h^{-1}$ defines a continuation homomorphism $h \circ \Phi_{H_{01}^g} \circ h^{-1}$ where $\Phi_{H_{01}^g}$ is a continuation defined by H_{01}^g . Thus,

$$\begin{aligned} \Psi_g \circ \Psi_h &= \Phi_{H_{01}^g} \circ g \circ \Phi_{H_{01}^h} \circ h \\ &= \Phi_{H_{01}^g} \circ (g \circ \Phi_{H_{01}^h} \circ g^{-1}) \circ (gh) \\ &= \Phi_{H_{01}^g} \circ (\Phi_{H_{01}^h \circ g^{-1}}) \circ (gh). \end{aligned}$$

The composition $\Phi_{H_{01}^g} \circ (\Phi_{H_{01}^h \circ g^{-1}})$ of two continuation homomorphisms is chain homotopic to the continuation map $\Phi_{H_{01}^{gh}}$ via homotopy $\tilde{\sigma}_{g,h}$ and we define $\sigma_{g,h} := \tilde{\sigma}_{g,h} \circ (gh)$ to obtain the formula (6.2).

This shows that the G -action is well-defined on morphism spaces of the category C . Now, we show that the composition is compatible with the

G -action. Naive G -action gives the following commutative diagram:

$$(6.3) \quad \begin{array}{ccc} CF(L_0, L_1; H_{01}) \times CF(L_1, L_2; H_{1,2}) & \xrightarrow{m_2} & CF(L_0, L_2; H_{o2}) \\ \downarrow g & & \downarrow g \\ CF(L_0, L_1; g(H_{01})) \times CF(L_1, L_2; g(H_{1,2})) & \xrightarrow{m_2^g} & CF(L_0, L_2; g(H_{o2})). \end{array}$$

In order to move back from the second line to the first line, we consider continuation homomorphisms $\Phi_{H_{01}^g}, \Phi_{H_{12}^g}$ and $\Phi_{H_{o2}^g}$, all of which we denote by Φ_1 for simplicity. It is not hard to show that there exist Φ_2 (the second component of A_∞ -homomorphism(functor) between two different perturbation data) satisfying the following relation:

$$(6.4) \quad \begin{aligned} & \Phi_1 m_2(x, y) + \Phi_2(m_1(x), y) + (-1)^{\deg' x} \Phi_2(x, m_1(y)) \\ & = m_2(\Phi_1(x), \Phi_1(y)) + m_1(\Phi_2(x, y)). \end{aligned}$$

This shows that the product is well-defined in Donaldson-Fukaya categories independent of perturbation data, and also implies its compatibility with the G -action when applied to $(g(x), g(y))$. The functor from $D \rightarrow C$ can be easily constructed using the isomorphisms $\{T_g\}_{g \in G}$ from the pull-back spin bundles to the original one. □

7. Energy zero subgroups for non-exact cases

From now on, we drop the exactness assumption and discuss the G -Floer-Novikov theory of a general symplectic manifold (see Section 4). As observed in G -Novikov theory, we need to find a subgroup of *energy zero* elements. We will call this set G_α of energy zero elements of G , which is an analogue of G_η in G -Novikov theory in Section 3. For each energy zero element, we will assign a spin structure on the Lagrangian bundle data associated to it, using the pre-fixed isomorphisms $\{T_g\}_{g \in G}$. The composition of energy zero elements will reveal the necessity of the condition that two Lagrangian should have the same spin profiles to define a group action on their Floer cochain complex.

Let L_0 and L_1 be G -invariant Lagrangian submanifolds of M , transversally intersecting with each other. Assume that both L_0 and L_1 are connected, compact, oriented and they admit spin structures which are preserved by the G -action in the sense of Assumption 5.1. In case of orientation reversing action, we assume that both L_0 and L_1 have orientation reversing G -actions and work under Assumption 5.14. We set the notations as follows:

- A_{g,L_i} : the action of $g \in G$ on L_i ,
- A_{g,L_i}^{SO} : the induced action of g on the frame bundle of L_i ,
- A_{g,L_i}^{spin} : the specified lift of A_{g,L_i}^{SO} on the spin bundle of L_i
 (or $T_{g,L_i} : (A_{g,L_i})^* P_{spin}(L_i) \xrightarrow{\cong} P_{spin}(L_i)$)

for $i = 0, 1$. The choice of A_{g,L_i}^{spin} above gives rise to spin profiles spf_{L_i} of L_i , correspondingly.

We choose a base path l_0 of the space of paths $\Omega(L_0, L_1)$ so that $g \cdot l_0 \neq h \cdot l_0$ for $g \neq h$. (This is not essential, but simplifies expositions). The naive G -action on $\Omega(L_0, L_1)$ will be written as $g(l)(t) = g(l(t))$ for $l \in \Omega(L_0, L_1)$. Consider the connected component $\Omega(L_0, L_1; l_0)$ containing l_0 . Note that $g(l)$ may not lie in $\Omega(L_0, L_1; l_0)$. Hence, we take a subgroup preserving the connected component as follows.

Definition 7.1. We define the subgroup G_{l_0} of G as

$$G_{l_0} := \{g \in G \mid g(l_0) \in \Omega(L_0, L_1; l_0)\}.$$

We will reduce it further to the smaller subgroup, G_α of energy zero elements in G_{l_0} . For $g \in G_{l_0}$, we have a surface connecting l_0 and $g(l_0)$. Namely, there exists a surface $w_g : [0, 1] \times [0, 1] \rightarrow M$, such that

$$(7.1) \quad \begin{aligned} w_g(0, t) &= l_0(t) \\ w_g(1, t) &= g(l_0)(t) \\ w_g(s, 0) &\in L_0 \\ w_g(s, 1) &\in L_1. \end{aligned}$$

The symplectic area and the Maslov index of w are defined as follows. The symplectic area of w is simply defined by $\mathcal{A}(w_g, g(l_0)) = \int w_g^* \omega$. For the Maslov index of w , we construct a loop of Lagrangian subspaces along $w_g(\partial[0, 1]^2)$ in a canonical way. Recall that we have the pre-fixed Lagrangian path λ_{l_0} along l_0 . Then, $g(\tilde{\lambda}_{l_0})$ is a Lagrangian path along $g(l_0)$ from $T_{g(p_0)}L_0$ to $T_{g(p_1)}L_1$. (We use the orientation reversal $g(\tilde{\lambda}_{l_0})^{op}$ if g is orientation reversing). Along $w_g(s, i)$ for $i = 0, 1$, we consider $T_{w_g(s,i)}L_i$ for $s \in [0, 1]$. The concatenation of the above paths produces a bundle \mathcal{L}_{w_g} on $\partial[0, 1]^2$ which is a Lagrangian sub-bundle of w_g^*TM on $[0, 1]^2$. The Maslov index of \mathcal{L}_{w_g} is well-defined, and denoted by $\mu(w_g, g(l_0))$.

We will require w_g to have zero symplectic area and zero Maslov index, but given a general $g \in G_{l_0}$, such w_g may not necessarily exist.

Definition 7.2. We define

$$G_\alpha = \{g \in G \mid \exists w_g \text{ with } \mathcal{A}(w_g, g(l_0)) = \mu(w_g, g(l_0)) = 0\}.$$

Elements of G_α are called *energy zero elements*.

Given $g \in G_\alpha$, there can be several choices of w_g with zero symplectic area and zero Maslov index. However, all w_g 's satisfying $\mathcal{A}(w_g, g(l_0)) = \mu(w_g, g(l_0)) = 0$ are Γ -equivalent to each other. (See Definition 4.1 for the Γ -equivalence relation.)

Lemma 7.3. G_α forms a subgroup of G .

Proof. Let g and h be elements of G_α . Then, there are $(w_g, g(l_0))$ and $(w_h, h(l_0))$ whose energies and Maslov indices are both zero. We make a concatenation

$$(7.2) \quad w_{gh} := w_g \star (g(w_h)).$$

Then, $(w_{gh}, (gh)(l_0))$ connects l_0 and $(gh)(l_0)$ and hence, gh is accompanied with the path w_{gh} satisfying

$$\mathcal{A}((w_{gh}, (gh)(l_0))) = \mu(w_{gh}, (gh)(l_0)) = 0$$

since \mathcal{A} and μ are invariant under G -action. □

Now, we will associate a canonical spin structure of \mathcal{L}_{w_g} to each w_g so that we can define the action of G_α on the orientation spaces for the generators of the Floer complex. We will see that there may be an obstruction on the cocycle condition for the group action due to the difference spin structures on $w_g \star g(w_h)$ and w_{gh} (Proposition 7.4).

Recall that $\mathcal{L}_{w_g}|_{\{0\} \times [0,1]} = \lambda_{l_0}$ has a preferred trivialization $\sigma : [0, 1] \times \mathbb{R}^n \rightarrow \tilde{\lambda}_{l_0}$ and that the spin structure $P_{spin}(\lambda_{l_0})$ for λ_{l_0} is fixed by one of its lifting $\tilde{\sigma} : [0, 1] \times Spin(n) \cong P_{spin}(\lambda_{l_0})$ (4.8). Over $[0, 1] \times \{0\}$ (resp. $[0, 1] \times \{1\}$) we have $P_{spin}(L_0)$ (resp. $P_{spin}(L_1)$). Gluing of two spin structures at $(0, i)$ is done by $\iota_i \circ \tilde{\sigma}^{-1}$ for $i = 0, 1$ as explained in (4.8). It remains to specify spin structure of \mathcal{L}_{w_g} along $\{1\} \times [0, 1]$ and how to glue it to $P_{spin}(L_i)$'s.

Let us assume for a moment that the g -action preserves orientations of L_0 and L_1 . By g -action, the reference path l_0 is mapped to $g(l_0)$. Then, the Lagrangian path $g(\tilde{\lambda}_{l_0})$ over $g(l_0)$ from $T_{g(p_0)}L_0$ to $T_{g(p_1)}L_1$ can be trivialized

by $g \circ \sigma$:

$$[0, 1] \times \mathbb{R}^n \cong g(\tilde{\lambda}_{l_0}).$$

We take $(A_{g^{-1}})^*(P_{spin}(\tilde{\lambda}_{l_0}))$ as a spin structure $P_{spin}(g(\tilde{\lambda}_{l_0}))$. From $\tilde{\sigma}$, we get an induced isomorphism

$$(7.3) \quad \tilde{g\sigma} : [0, 1] \times Spin(n) \cong P_{spin}(g(\tilde{\lambda}_{l_0})).$$

We need to define an analogue of ι_i at $g(p_i)$ to identify two spin bundles there. ($l_0(i) = p_i$ for $i = 0, 1$.) In fact, $T_{g,L_i} : (A_{g^{-1}})^*P_{spin}L_i \rightarrow P_{spin}L_i$ comes into play to glue $P_{spin}(g(\tilde{\lambda}_{l_0}))$ with $P_{spin}(L_i)$ at $g(p_i)$. Note that $\iota_i : Spin(n) \rightarrow P_{spin}(L_i)_{p_i}$ defines a natural embedding, which we again denote by

$$\iota_i : Spin(n) \rightarrow (A_{g^{-1}})^*P_{spin}L_i|_{g(p_i)}.$$

Consider its composition with T_{g,L_i} :

$$T_{g,L_i} \circ \iota_i : Spin(n) \rightarrow P_{spin}(L_i)_{g(p_i)}.$$

We see that $T_{g,L_i} \circ \iota_i \circ (\tilde{g\sigma})^{-1}$ glues $P_{spin}(L_i)$ and $P_{spin}(g(\tilde{\lambda}_{l_0}))$ at $g(p_i)$. (See Figure 5) Therefore, we have described the canonical spin structure for \mathcal{L}_{w_g} , which depends on the pre-fixed choice of T_{g,L_i} .

If g is an orientation reversing action for both L_0 and L_1 , we instead use the orientation reversal $(A_g)_*\tilde{\lambda}_{l_0}^{op} = g(\tilde{\lambda}_{l_0})^{op}$ along $g(l_0)$, whose end points can be identified with $T_{g(p_0)}L_0$ and $T_{g(p_1)}L_1$. Let $\sigma_{SO} : [0, 1] \times SO(\mathbb{R}^n) \rightarrow \tilde{\lambda}_{l_0}$ be the trivialization of the frame bundle of $\tilde{\lambda}_{l_0}$ induced from σ . If $(\mathbb{R}^n)^{op}$ denotes \mathbb{R}^n with the opposite orientation, then σ_{SO} leads to the trivialization $\sigma_{SO}^{op} : [0, 1] \times SO((\mathbb{R}^n)^{op}) \rightarrow \tilde{\lambda}_{l_0}^{op}$. Take an isomorphism between $SO(\mathbb{R}^n)$ and $SO((\mathbb{R}^n)^{op})$, given by an element $O \in O(n) \setminus SO(n)$.

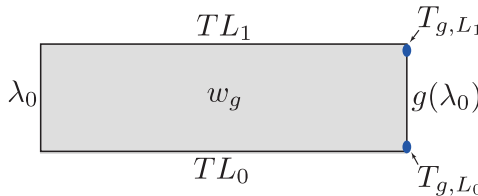

Figure 5: The canonical spin structure for \mathcal{L}_{w_g} .

From the extension $\tilde{\sigma} : [0, 1] \times Spin(\mathbb{R}^n) \xrightarrow{\cong} P_{spin}(\tilde{\lambda}_{l_0})$, we have $\tilde{\sigma}^{op} : [0, 1] \times Spin((\mathbb{R}^n)^{op}) \xrightarrow{\cong} P_{spin}(\tilde{\lambda}_{l_0}^{op})$ which are isomorphic to the former by

multiplying a lift $\tilde{O} \in Pin(n) \setminus Spin(n)$. We also have $\widetilde{g\sigma}^{op} : [0, 1] \times Spin((\mathbb{R}^n)^{op}) \xrightarrow{\cong} P_{spin}(g\widetilde{\lambda}_{l_0}^{op})$. We next take $A_{g^{-1}}^*(P_{spin}(\widetilde{\lambda}_{l_0}^{op}))$ as the spin structure of $g(\widetilde{\lambda}_{l_0}^{op})$, and glue $P_{spin}(L_i)$ and $P_{spin}(g(\widetilde{\lambda}_{l_0}^{op}))$ using $T_{g,L_i} \circ \iota_i \circ (\widetilde{g\sigma} \circ \tilde{O})^{-1}$.

So far, we have described the canonical spin structure associated to the Lagrangian sub-bundle \mathcal{L}_{w_g} over the boundary of w_g . For the cocycle condition of the group action in the next section, we compare the spin structures of $w_g, g(w_h)$ and w_{gh} . Here, we may take $w_{gh} = w_g \star g(w_h)$ as in Lemma 7.3 so that the Lagrangian sub-bundle over the boundaries of w_{gh} and $w_g \star g(w_h)$ are exactly the same, but the induced spin structures may be different (other choices of w_{gh} are related to this one by Γ -equivalence, and so are their orientation spaces).

One way to define a spin structure on the bundle data over w_{gh} is using T_{gh,L_i} as above (Figure 5).

Here is a description of a different way to define a spin structure on $w_g \star g(w_h)$. On w_g , we use a spin structure given in Figure 5. Now let us consider $g(w_h)$. We glue the spin structure on the left vertical edge of $g(w_h)$ using $T_{g,L_i} \circ \iota_i \circ \widetilde{g\sigma}^{-1}$ in the same that we glue the right vertical edge of w_g so that the gluing of w_g and $g(w_h)$ along this edge is well defined. For the right vertical edge of $g(w_h)$, the gluing process involves both T_{g,L_i} and T_{h,L_i} . Recall that we have used

$$(T_{h,L_i})_{h(p_i)} \circ \iota_i : Spin(n) \rightarrow P_{spin}(L_i)_{h(p_i)}$$

for gluing at the right vertical edge of w_h where we trivialize $P_{spin}(h(\widetilde{\lambda}_{l_0}))_{p_i}$ by $\widetilde{h\sigma}^{-1}$.

On the end point $gh(p_i)$ of the right vertical edge of $g(w_h)$,

$$\begin{aligned} (T_{g,L_i})_{gh(p_i)} \circ ((A_{g^{-1}})^* T_{h,L_i})_{gh(p_i)} \circ \iota_i : Spin(n) &\rightarrow P_{spin}(L_i)_{h(p_i)} \\ &\rightarrow P_{spin}(L_i)_{gh(p_i)} \end{aligned}$$

is used to glue the spin structure $gh(\widetilde{\lambda}_{l_0})$ on this edge with that on the horizontal edge. Here, $gh(\widetilde{\lambda}_{l_0})_{p_i}$ is identified with $Spin(n)$ via $\widetilde{gh\sigma}^{-1}$. Spin structures on horizontal edges are simply come from those on L_0 and L_1 .

Hence, we have two possibly different spin structures on $w_{gh} = w_g \star g(w_h)$.

Proposition 7.4. *The difference of the canonical orientations of $\det(\bar{\partial}_{w_{gh}})$ from these two spin structures is given by*

$$(-1)^{\text{spf}_{L_0}(g,h) + \text{spf}_{L_1}(g,h)}.$$

Proof. To compare two orientations, we consider $w(g, h) := w_g \star g(w_h) \star \overline{w_{gh}}$ by gluing $w_g \star g(w_h)$ with the reverse of w_{gh} , denoted as $\overline{w_{gh}}$. The spin structures on $w_g \star g(w_h)$ and $\overline{w_{gh}}$ are glued as follows. Spin structures on end points $gh(p_i)$ of the right vertical edge of $g(w_h)$ and the left vertical edge of $\overline{w_{gh}}$ at p_i can be glued by

$$\begin{aligned} T_{g,L_i} \circ (A_{g^{-1}})^* T_{h,L_i} \circ (T_{gh,L_i})^{-1} &: P_{\text{spin}}(L_i) \xrightarrow{\iota_i} \text{Spin}(n) \xrightarrow{\iota_i^{-1}} P_{\text{spin}}(L_i)_{h(p_i)} \\ &\rightarrow P_{\text{spin}}(L_i)_{gh(p_i)} \end{aligned}$$

This is equivalent to the obvious gluing of $g(w_h)$ and $\overline{w_{gh}}$ at a point in the vertical edges over which both spin structures are already trivialized by $\widetilde{gh\sigma}$. See Figure 6.

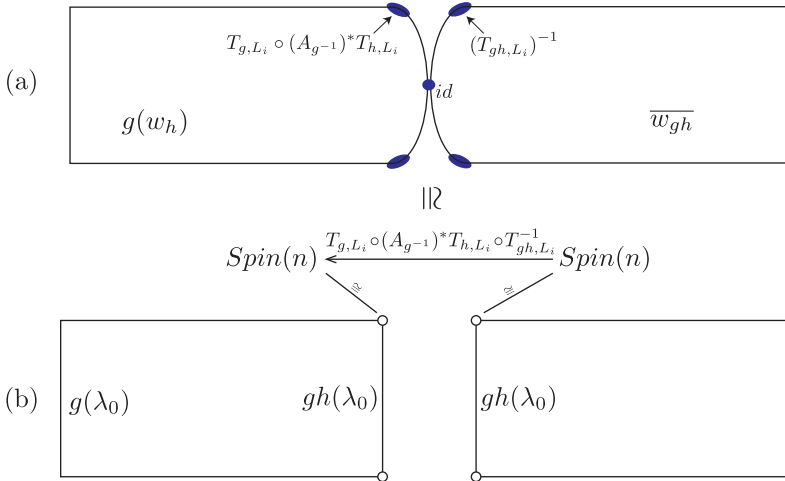

Figure 6: The spin structure on $w(g, h)$.

This shows that the difference between two spin structures is the gluing occurring at $gh(p_i)$ for $i = 0, 1$, which is given by

$$T_{g,L_i} \circ (A_{g^{-1}})^* T_{h,L_i} \circ (T_{gh,L_i})^{-1}$$

This is precisely the spin profile $\text{spf}_{L_i}(g, h)$ for L_i . Therefore, the difference is given by the product $(-1)^{\text{spf}_{L_0}(g, h)} \cdot (-1)^{\text{spf}_{L_1}(g, h)}$ and this proves the proposition. \square

Note that if L_0 and L_1 have the same spin profiles, then the difference $(-1)^{\text{spf}_{L_0}(g, h) + \text{spf}_{L_1}(g, h)}$ of two orientations cancel out, which will allow us to define group actions in the next section.

8. Group actions on Floer-Novikov complexes

In this section, we will define G_α -action (Definition 7.2) on the Floer Novikov complex of (L_0, L_1) when spin profiles of L_0 and L_1 coincide. As before, we assume that $\text{spf}_{L_0} = \text{spf}_{L_1}$ holds strictly, which does not harm the generality. (See the discussion below Assumption 6.5.)

For $g \in G_\alpha$, we will use the bounding surface w_g connecting the base path l_0 and $g(l_0)$ of zero symplectic area and zero Maslov index. We first explain the geometric action of G_α on the Novikov cover defined by gluing w_g in an appropriate way. Then, we will see how this action induces that between orientation spaces associated with generators of the Floer complex. The orientation analysis for w_g made in the previous section will be used crucially for this.

8.1. Group actions on the Novikov covering $\tilde{\Omega}(L_0, L_1; l_0)$

Recall from Subsection 4.1 that we have defined the universal covering space of the path space $\Omega(L_0, L_1; l_0)$ by $\tilde{\Omega}_{univ}(L_0, L_1; l_0)$, and refined it to get a smaller covering $\tilde{\Omega}(L_0, L_1; l_0)$ by introducing Γ -equivalence relation.

The G -action on M gives a naive G -action on path spaces such that

$$(8.1) \quad g((w, l)) \in \tilde{\Omega}_{univ}(L_0, L_1; g(l_0)), \quad g((w, l)) = (g(w), g(l)),$$

for $(w, l) \in \tilde{\Omega}_{univ}(L_0, L_1; l_0)$, where $g(w)(s, t) := g(w(s, t))$. Since this naive G -action changes the base path from l_0 to $g(l_0)$, it does *not* give the correct G -action for Floer-Novikov complex. Alternatively, we define the G_α -action on $\tilde{\Omega}(L_0, L_1; l_0)$ in the following way. For $g \in G_\alpha$, we take an energy zero path w_g satisfying $\mathcal{A}(w_g, g(l_0)) = \mu(w_g, g(l_0)) = 0$. Then, the G_α -action on $\tilde{\Omega}(L_0, L_1; l_0)$ is defined by first taking the naive g -action and then attaching w_g .

Definition 8.1. We define the action of

$$G_\alpha, G_\alpha \times \tilde{\Omega}(L_0, L_1; l_0) \rightarrow \tilde{\Omega}(L_0, L_1; l_0),$$

by

$$(8.2) \quad (g, [w, l]) \mapsto [w_g \star (g(w)), g(l)] =: g \cdot [w, l].$$

(See Figure 7.)

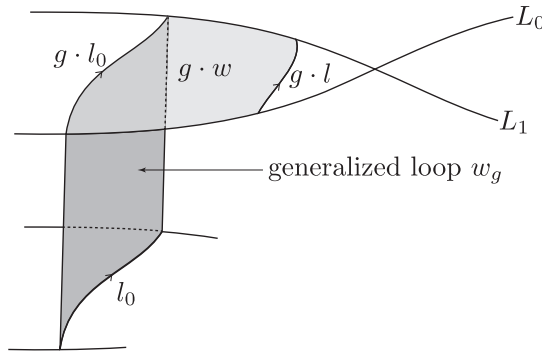

Figure 7: G_α -action on $\tilde{\Omega}(L_0, L_1; l_0)$.

Lemma 8.2. (8.2) provides a well-defined G_α -action on $\tilde{\Omega}(L_0, L_1; l_0)$

Proof. One may choose a different w'_g with $\mathcal{A}(w'_g, g(l_0)) = \mu(w'_g, g(l_0)) = 0$ to define g -action, or choose a different representative $[w', l]$ of $[w, l]$, but it is elementary to check that these provide the same map (8.2) up to Γ -equivalence. \square

Now, we prove an analogue of Lemma 3.9.

Lemma 8.3. The covering map $\pi : \tilde{\Omega}(L_0, L_1; l_0) \rightarrow \Omega(L_0, L_1; l_0)$ is G_α -equivariant. Moreover the action of G_α and that of deck transformation group $\Pi(L_0, L_1; l_0)$ on $\tilde{\Omega}(L_0, L_1; l_0)$ commute with each other.

Proof. The projection map sends $[w_g \star (g(w)), g(l)]$ to $g(l)$, hence the first claim follows.

Suppose that an element $c \in \Pi(L_0, L_1; l_0)$ is represented by a loop C at l_0 in the path space Ω . Then,

$$g \cdot c \cdot [w, l] = [w_g \star (g(C)) \star (g(w)), g(l)].$$

On the other hand,

$$c \cdot g \cdot [w, l] = [C \star w_g \star (g(w)), g(l)].$$

Their difference is represented by the cylinder

$$(8.3) \quad w_g \star (g(C)) \star \overline{w_g} \star \overline{C}.$$

Note that $w_g \star g(C) \star \overline{w_g}$ and \overline{C} have the opposite energies, Maslov indices. Hence (8.3) has vanishing energy and Maslov index, which implies

$$(8.4) \quad g \cdot c \cdot [w, l] = c \cdot g \cdot [w, l].$$

□

Recall that the Floer action functional \mathcal{A} on $\tilde{\Omega}(L_0, L_1; l_0)$ is defined by $\mathcal{A}([w, l]) = \int w^* \omega$ for $[w, l]$ in $\tilde{\Omega}(L_0, L_1; l_0)$ and, The set $Cr(L_0, L_1; l_0)$ of critical points of \mathcal{A} consists of the pairs $[w, l_p]$ where l_p is the constant path with $p \in L_0 \cap L_1$. $Cr(L_0, L_1; l_0)$ is invariant under $\Pi(L_0, L_1; l_0)$.

The following lemma demonstrates that \mathcal{A} is compatible with the G_α -action.

Lemma 8.4. *\mathcal{A} is invariant under G_α -action on $\tilde{\Omega}(L_0, L_1; l_0)$, and the set $Cr(L_0, L_1; l_0)$ is invariant under the action of G_α .*

Proof. The G_α -invariance of \mathcal{A} follows from the G -invariance of ω and the definition of G_α -action. In particular, the set of critical points of \mathcal{A} is preserved by G_α . □

Let $p \in L_0 \cap L_1$ and suppose that the constant path l_p lies in the component $\Omega(L_0, L_1; l_0)$. We consider the relation between G_α and the isotropy group G_p , which is an analogue of Lemma 3.7.

Lemma 8.5. *For $p \in L_0 \cap L_1$, we have*

$$G_p \subset G_\alpha.$$

In general, if there exists a path from L_0 to L_1 which is fixed by $g \in G$, then g belongs to G_α .

Proof. If $g \in G_p$, then $g \in G_{l_0}$ since it preserves the connected component of $\Omega(L_0, L_1)$ containing l_p . To see that $g \in G_\alpha$, take $(u, l) \in \widetilde{\Omega}_{univ}(L_0, L_1; l_0)$, where u is a bounding surface from l_0 to l_p . Then, $g(u)$ is a bounding surface from $g(l_0)$ to $g(l_p) = l_p$. Setting $w_g := u \star \overline{g(u)}$, we get a bounding surface from l_0 to $g(l_0)$ which has vanishing energy and Maslov index. The general case can be proved similarly. \square

Definition 8.6. We denote by $(G_\alpha)_{[w,l]}$ the isotropy group at $[w, l] \in \widetilde{\Omega}(L_0, L_1; l_0)$ for the G_α -action.

Lemma 8.7. *We have*

$$(G_\alpha)_{[w,l_p]} = G_p.$$

Proof. For $g \in G_p$, take $w_g := w \star \overline{g(w)}$ as in the proof of lemma 8.5. Observe that the g -action on $[w, l_p]$ is nothing but $[w_g \star g(w), l_p]$. Since $w_g \star g(w) = w \star \overline{g(w)} \star g(w)$ which is Γ -equivalent to w , we see that w_g fixes the Γ -equivalent class of $[w, l_p]$.

The other direction $(G_\alpha)_{[w,l_p]} \subset G_p$ is easy to check. \square

8.2. G_α -action on the critical points and their orientation spaces

The G_α -action on the orientation spaces are crucial ingredient for defining a group action on Floer theory of Lagrangian intersections. This signifies that as in the Morse case, we do *not* want the group action on the set of critical points of the Novikov-Floer complex, but rather on the set of the orientation spaces associated to critical points.

So far, we have considered the G_α -action on the Novikov covering $\widetilde{\Omega}(L_0, L_1; l_0)$. We next study how this G_α -action induces the action on the complex $CF_{R,l_0}^*(L_0, L_1)$ in (4.14) (generated by orientation spaces). The key part of the construction is how to define an action on the orientation spaces associated to critical points.

Recall that the orientation space $\Theta_{[w,l_p]}^-$ can be assigned to each Γ -equivalence class $[w, l_p] \in Cr(L_0, L_1; l_0)$ without ambiguity. We have identified the orientation spaces for (w', l_p) and (w, l_p) in the Γ -equivalence class using the canonical spin structure on the cylinder C representing the Γ -equivalence between them (Lemma 4.5).

Now, we define the group action on the orientation space $\Theta_{[w,l_p]}^-$ associated to $[w, l_p] \in Cr(L_0, L_1; l_0)$. It will be soon revealed that the group action below is only well-defined if the spin profile of L_0 and L_1 are the same.

Definition 8.8. Given $g \in G_\alpha$, take w_g satisfying

$$\mathcal{A}(w_g, g(l_0)) = \mu(w_g, g(l_0)) = 0.$$

Then, the action on Floer complex

$$G_\alpha \times CF_{R,l_0}^*(L_0, L_1) \mapsto CF_{R,l_0}^*(L_0, L_1)$$

is defined by the linear map Φ_g^Θ on generators

$$(8.5) \quad \Phi_g^\Theta : \Theta_{[w, l_p]}^- \mapsto \Theta_{[w_g \star g(w), l_{g(p)}]}^-.$$

Φ_g^Θ is defined as a composition

$$(8.6) \quad \Theta_{[w, l_p]}^- \xrightarrow{A_g^\Theta} \Theta_{[g(w), l_{g(p)}]}^- \xrightarrow{\text{gluing}} \Theta_{[w_g \star g(w), l_{g(p)}]}^-$$

(See Figure 8.)

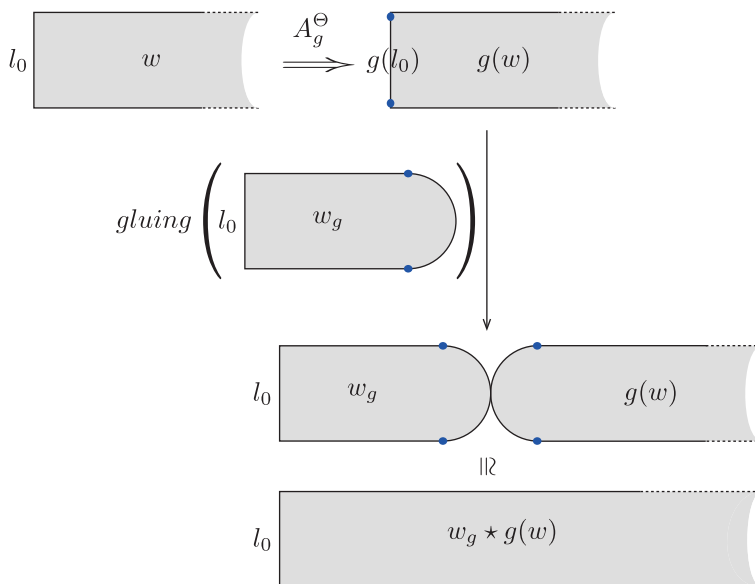

Figure 8: Two steps of Φ_g^Θ .

We will see in Proposition 8.9 below that the action defined is independent of choice of w_g . Let us first closely look into each part of the map (8.6).

We only explain the case when G_α is orientation preserving. One can proceed similarly for the other case, which we omit.

(1) The first map A_g^\ominus is the map given by the naive G -action. Namely, taking g -action to $[w, l_p]$ and the associated Lagrangian bundle λ_w , we get a generator $[g(w), l_{g(p)}]$ and the Lagrangian bundle $\lambda_{g(w)}$ along ∂Z_- . Then, we consider two Cauchy-Riemann problems on Z_- with Lagrangian boundary conditions given by λ_w and $\lambda_{g(w)}$ in w^*TM and $g(w)^*TM$ respectively. Note that the naive g -action sends the bundle pair (w^*TM, λ_w) to $(g(w)^*TM, \lambda_{g(w)})$. This induces an action of g between two Cauchy-Riemann problems (J is G -invariant), and in particular, one can send kernel and cokernel of $\bar{\partial}_{\lambda_w, Z_-}$ to those of $\bar{\partial}_{\lambda_{g(w)}, Z_-}$. They define a map A_g^\ominus from $\det(\bar{\partial}_{\lambda_w, Z_-})$ to $\det(\bar{\partial}_{\lambda_{g(w)}, Z_-})$ by Definition 4.3.

(2) The second map *gluing* is needed from G -Novikov theory, since A_g^\ominus image gives a path from $g(l_0)$ not l_0 . Hence, we restricted to the subgroup G_α , and consider the gluing map of determinant spaces. To define this map, we need to specify the choices of spin structures. For this, we need to define the spin structure of $\lambda_{g(w)}$ carefully. The desired spin structure of $\lambda_{g(w)}$ should have the following property. We already have a prescribed spin structure on λ_{w_g} . Hence, if we glue λ_{w_g} , with $\lambda_{g(w)}$, we will obtain one spin structure on the concatenation $\lambda_{w_g \star g(w)}$. But $w_g \star g(w)$ also has another spin structure induced from the spin structures of L_0 and L_1 . We would like to have these two spin structures being equal to each other.

For this purpose, we define the spin structure of $\lambda_{g(w)}$ as follows. Along top and bottom edges of Z_- we have spin structures induced from $P_{spin}(L_1)$, and $P_{spin}(L_0)$. Since $g(\lambda_{l_0})$ lies over the circular boundary of Z_- for $g(w)$, it is natural to consider $P_{spin}(g(\lambda_{l_0}))$ along this region. Then, we glue it to $P_{spin}(L_i)$ making use of $T_{g, L_i} \circ \iota_i \circ \widetilde{g\sigma}^{-1}$ for $i = 0, 1$ as before. Observe that the circular boundary part of Z_- has the same spin structure as the right vertical edge of w_g . What we obtain after gluing w_g and $g(w)$ is indeed the canonical spin structure of $\lambda_{w_g \star g(w)}$ (produced by the spin structure of $L_0, L_1, P_{spin}(l_0)$ and $\iota_i \circ \sigma^{-1}$). This is because contributions $T_{g, L_i} \circ \iota_i \circ \widetilde{g\sigma}^{-1}$ appear twice in the gluing above (once in the spin structure of w_g (right edge) and next in the spin structure of $g(w)$ (left edge)), and hence they cancel out.

We are now ready to define the second map *gluing*. *gluing* is an isomorphism

$$\Theta_{[g(w), l_{g(p)}]}^- \rightarrow \Theta_{[w_g \star g(w), l_{g(p)}]}^-.$$

obtained from the gluing of w_g and $g(w)$ at a point using (4.10). To be specific, we take $S_4 = D^2$ (instead of $[0, 1]^2$) and $F_4 = \lambda_{w_g}$, and $S_5 = Z_-$ and $F_5 = \lambda_{g(w)}$, and $S_6 = Z_-$ and $F_6 = \lambda_{w_g \star g(w)}$.

Proposition 8.9. *The action of G_α on $CF_{R,l_0}^*(L_0, L_1)$ is well-defined.*

Proof. We first check that the map Φ_g^\ominus is independent of the choice of an energy zero path w_g for $g \in G_\alpha$. Let $w_{g,1}$ and $w_{g,2}$ be two energy zero paths from l_0 to $g(l_0)$. If we apply the action of g to $[w, l_p]$ ($p \in L_0 \cap L_1$) using these paths, we have two elements $[w_{g,1} \star g(w), l_{g(p)}], [w_{g,2} \star g(w), l_{g(p)}]$ which are Γ -equivalent to each other. Recall from Lemma 4.5 that the orientation spaces of these two elements are identified by the cylinder C satisfying

$$C \cong w_{g,2} \star g(w) \star \overline{g(w)} \star \overline{w_{g,1}} \cong w_{g,2} \star \overline{w_{g,1}}.$$

Observe that $w_{g,2} \star \overline{w_{g,1}}$ is a loop from l_0 to itself that gives an Γ -equivalence. Therefore, we need to compare the canonical structure on it with the spin structures on $w_{g,2} \star \overline{w_{g,1}}$ coming from the gluing of spin structures on $w_{g,i}$'s. However, since the spin structures on vertical edges of $w_{g,2}$ and $\overline{w_{g,1}}$ corresponding to $g(l_0)$ are exactly the same so that the effects of T_{g,L_i} cancel out. Thus, the following diagram commutes

$$\begin{array}{ccc}
 & \det(\bar{\partial}_{w_{g,1} \star g(w)}) & \\
 (-) \star w_{g,1} \nearrow & & \downarrow (-) \star C \\
 \Theta_{[w, l_p]}^- & & \det(\bar{\partial}_{w_{g,2} \star g(w)}) \\
 (-) \star w_{g,2} \searrow & & \\
 & &
 \end{array}$$

which implies that the action does not depend on the choice of w_g .

We next show that the cocycle condition of the group action holds, i.e., $\Phi_g^\ominus \circ \Phi_h^\ominus = \Phi_{gh}^\ominus$ for $g, h \in G_\alpha$. For this, we take energy zero paths w_g, w_h and w_{gh} and apply the actions to $[w, l_p]$ to get

$$[w_g \star g(w_h) \star gh(w), l_{gh(p)}] \quad \text{and} \quad [w_{gh} \star gh(w), l_{gh(p)}].$$

We may take $w_{gh} = w_g \star g(w_h)$ and other choices are Γ -equivalent to it.

We have already compared the two possible induced spin structures of w_{gh} in the last section. Recall from Proposition 7.4 that their difference affects the orientation spaces exactly by the sign $(-1)^{\text{spf}_{L_0}(g,h)+\text{spf}_{L_1}(g,h)}$, which is 1 in our case since $\text{spf}_{L_0}(g,h) = \text{spf}_{L_1}(g,h)$. This completes the proof. \square

Lastly, the G_α -action on the Floer cochain complex is the linear extension of G_α -action on $Cr(L_0, L_1; l_0)$ and this is compatible with what actually happens in geometry from the identity (8.4). (See Definition 4.2 for the precise definition of $\Lambda^R(L_0, L_1; l_0)$.)

Proposition 8.10. *G_α -action on $CF_{R,l_0}^*(L_0, L_1)$ is $\Lambda^R(L_0, L_1; l_0)$ -linear.*

8.3. Orbifold Novikov ring

We present an enlarged Novikov ring $\Lambda_{orb}^R(L_0, L_1; l_0)$ for orbifold Floer cohomology which is an analogue of $\Lambda_{[\eta]}^{rob}$ in Subsection 3.3. Heuristically, $\Lambda_{orb}^R(L_0, L_1; l_0)$ contains elements in $G \setminus G_\alpha$ as there exists a path from l_0 to $g(l_0)$ for $g \notin G_\alpha$ which gives rise to a genuine loop of paths between $[L_0/G]$ and $[L_1/G]$ which increases (or decreases) the energy non-trivially.

Consider the set of homotopy classes of “generalized” paths in $\Omega(L_0, L_1; l_0)$ which begin at l_0 and end at $g(l_0)$ for $g \in G$. Then, we take the quotient of it by the set of classes which can be represented by energy, Maslov zero paths. (I_ω and I_μ are extended to generalized paths in the obvious way.) Denote this quotient by $\Pi(L_0, L_1; l_0)_{orb}$. In particular, $\Pi(L_0, L_1; l_0)_{orb}$ contains an element represented by a path w whose end point is $g(l_0)$ for $g \in G \setminus G_\alpha$. There is an exact sequence

$$1 \rightarrow \Pi(L_0, L_1; l_0) \rightarrow \Pi(L_0, L_1; l_0)_{orb} \rightarrow G/G_\alpha \rightarrow 1$$

analogously to the third line of the diagram (3.6).

Definition 8.11. $\Lambda_{orb}(L_0, L_1; l_0)$ is defined by the completion of the group ring of $\Pi(L_0, L_1; l_0)_{orb}$ over R .

By mimicking the construction in Definition 3.17, the G_α -invariant part $CF_{R,l_0}^*(L_0, L_1)^{G_\alpha}$ admits a structure of $\Lambda_{orb}(L_0, L_1; l_0)$ -module. Note that

$\Lambda_{orb}(L_0, L_1; l_0)$ has the \mathbb{Z} -grading induced by I_μ and there is a natural inclusion $\Lambda^R(L_0, L_1; l_0) \rightarrow \Lambda_{orb}^R(L_0, L_1; l_0)$ which fits into the diagram

$$\begin{array}{ccc} \Lambda^R(L_0, L_1; l_0) & \longrightarrow & \Lambda_{nov}(R) \\ \downarrow & \nearrow & \\ \Lambda_{orb}^R(L_0, L_1; l_0) & & \end{array}$$

where $\Lambda_{orb}^R(L_0, L_1; l_0) \rightarrow \Lambda_{nov}$ is obtained by taking the energy and the Maslov index. We omit further details as this new coefficient ring will not be visible if we use the universal Novikov field. From now on, we will only use $\Lambda_{nov}(R)$ as our coefficient ring.

9. Equivariant transversality

Lagrangian Floer theory is built upon subtle data of J -holomorphic discs and strips. In order to have good moduli spaces of such maps, an appropriate perturbation scheme is required. Furthermore, we need equivariant transversality for the sake of group actions on Floer theory, and it is difficult to achieve both equivariance and transversality at once using simple methods.

We have shown that the algebraic technique due to Seidel can be hired to overcome this problem in section 6 for exact symplectic manifolds and Lagrangian submanifolds. Note that the bubbling off of discs does not occur in this case. Seidel developed a domain-dependent perturbation scheme for J -holomorphic strips and polygons which gives rise to the desired A_∞ -relations.

For the general case, however, disc bubblings do occur and the domain dependent perturbation is not good enough. Fukaya and Ono [24] introduced an abstract perturbation scheme called Kuranishi structure to achieve transversality. Fukaya-Oh-Ohta-Ono [25] have developed it further to cover the construction of the filtered A_∞ -structures. Note that Kuranishi structure is, in fact, a tool designed for attaining equivariant transversality more systematically with help of multi-sections. Hence, adding a finite group action to Kuranishi structure is not presumed to cause more difficulty. We will explain how to achieve equivariant transversality in this setup.

9.1. Brief review of Kuranishi structure

We refer readers to [24], [25, Appendix A], [28] for the definition and properties of Kuranishi structure. What we will carry out in this section is roughly as follows. Suppose a space \mathcal{M} admits a Kuranishi structure and a G -action. We shall show that there is an induced Kuranishi structure on \mathcal{M}/G whose multi-valued perturbation gives rise to G -equivariant multi-sections on \mathcal{M} if chosen suitably.

Let us explain in more detail. First we briefly explain the terms.

Definition 9.1. [25, A1.1] A Kuranishi neighborhood of a point p in a compact metrizable space X is a quintuple $(V_p, E_p, \Gamma_p, \psi_p, s_p)$ such that

- 1) V_p is a finite dimensional smooth manifold (possibly with boundary or corner);
- 2) E_p is a finite dimensional real vector space;
- 3) Γ_p is a finite group acting smoothly and effectively on V_p and linearly on E_p ;
- 4) s_p is a Γ_p -equivariant map $V_p \rightarrow E_p$;
- 5) $\psi_p : s_p^{-1}(0)/\Gamma_p \rightarrow U_p \subset X$ is a homeomorphism to a neighborhood U_p of $p \in X$.

Given a pair of neighborhoods $(V_p, E_p, \Gamma_p, \psi_p, s_p)$ and $(V_q, E_q, \Gamma_q, \psi_q, s_q)$ of $p \in X$ and $q \in \psi_p(s_p^{-1}(0)/\Gamma_p)$, a coordinate change [25, A1.3] is denoted as $(\hat{\phi}_{pq}, \phi_{pq}, h_{pq})$. Here, $h_{pq} : \Gamma_q \rightarrow \Gamma_p$ is an injective homomorphism, and $\phi_{pq} : V_{pq} \rightarrow V_p$ is an h_{pq} -equivariant smooth embedding from Γ_q -invariant open neighborhood V_{pq} of the origin in V_q to V_p , and $\hat{\phi}_{pq}$ is a compatible equivariant embedding of vector bundles $E_q \times V_{pq} \rightarrow E_p \times V_p$. These are required to satisfy additional properties which we omit. Note that a coordinate change may exist only in one direction.

Definition 9.2. [25, A1.5] A Kuranishi structure on X assigns a Kuranishi neighborhood $(V_p, E_p, \Gamma_p, \psi_p, s_p)$ for each $p \in X$ and a coordinate change $(\hat{\phi}_{pq}, \phi_{pq}, h_{pq})$ for each $q \in \psi_p(s_p^{-1}(0)/\Gamma_p)$ such that

- 1) $\dim V_p - \text{rank } E_p$ is independent of p , called virtual dimension of X ;

- 2) For $r \in \psi_q(s_q^{-1}(0) \cap V_{pq}/\Gamma_q), q \in \psi_p(s_p^{-1}(0)/\Gamma_p)$, there exists $\gamma_{pqr} \in \Gamma_p$ satisfying

$$h_{pq} \circ h_{qr} = \gamma_{pqr} \cdot h_{pr} \cdot \gamma_{pqr}^{-1}, \quad \phi_{pq} \circ \phi_{qr} = \gamma_{pqr} \cdot \phi_{pr}, \quad \hat{\phi}_{pq} \circ \hat{\phi}_{qr} = \gamma_{pqr} \cdot \hat{\phi}_{pr}.$$

If trying to perturb $\{s_p\}$ to make it transverse to zero section, one needs to construct perturbations inductively. Since a coordinate change may exist only in one direction, a clever choice of subcollection of Kuranishi neighborhoods is required. This subcollection should be ordered for inductive perturbations, and cover X . Such a choice is called a *good coordinate system*. (See [25, A.1.11].) One can always choose a good coordinate system, whose detailed construction has been given in part II of [28]. The proof goes by the induction on the dimension of V_p , and in each dimension, one glues several Kuranishi neighborhoods to obtain bigger Kuranishi neighborhoods and finally get a good coordinate system. There is a notion of tangent bundle of a space X with a Kuranishi structure, and also a notion of orientations on it, which we omit.

We now recall multi-sections of a Kuranishi structure. For $(V_p, E_p, \Gamma_p, \psi_p, s_p)$, consider the product of l copies of E_p , denoted as E_p^l , and endow it with the action of symmetric group S_l . Denote the quotient space by $\mathcal{S}^l(E_p) := E_p^l/S_l$, which has an induced action of Γ_p . There exists a Γ_p -equivariant map

$$tm_m : \mathcal{S}^l(E_p) \rightarrow \mathcal{S}^{lm}(E_p),$$

which sends $[a_1, \dots, a_l]$ to

$$[\underbrace{a_1, \dots, a_1}_{m \text{ copies}}, \dots, \underbrace{a_l, \dots, a_l}_{m \text{ copies}}].$$

Definition 9.3. [25, A1.19] An n -multisection s of $\pi : E_p \times V_p \rightarrow V_p$ is a Γ_p -equivariant map $V \rightarrow \mathcal{S}^n(E_p)$. It is said to be *liftable* if there exist $\tilde{s} = (\tilde{s}_1, \dots, \tilde{s}_n) : V_p \rightarrow E_p^n$ such that its composition with $\pi : E_p^n \rightarrow \mathcal{S}^n(E_p)$ is s . Here \tilde{s} needs not be Γ_p -equivariant. Each \tilde{s}_i is called a branch of s .

Liftable multisections will be considered always. Given an n -multisection, we obtain an nm -multi-section by composing it with tm_m map. An n -multisection s is equivalent to an m -multisection s' if their induced mn -multisections are the same. We identify equivalent multi-sections from now on. A lifted multisection is said to be transversal to zero if each of its branches is transversal to the zero section. Compatibilities of multi-sections can be handled in the same way as in [25] and we omit the details.

A family of multisections s_ϵ is said to converge to a Kuranishi map $s = \{s_p\}$ as $\epsilon \rightarrow 0$ if there exists n such that s_ϵ is represented by an n -multisection s_ϵ^n and s_ϵ^n converges to a representative of s .

Lemma 9.4. [25, A1.23] *Suppose that a good coordinate system of the Kuranishi structure over X is given, and that the Kuranishi structure has a tangent bundle. Then, there exists a family of multisections $\{s'_{p,\epsilon}\}$ such that it converges to $\{s_p\}_{p \in P}$ and $s'_{p,\epsilon}$'s are transversal to 0 for all $\epsilon > 0$.*

9.2. Kuranishi structure for equivariant transversality

A notion of group actions on a space with Kuranishi structure is introduced in [25, A1.3].

Definition 9.5. Let X be a space with Kuranishi structure. A homeomorphism $\phi : X \rightarrow X$ is called an automorphism of Kuranishi structure if the following holds: For $p \in X$ and $p' = \phi(p)$, there exist Kuranishi neighborhoods $(V_p, E_p, \Gamma_p, \psi_p, s_p), (V_{p'}, E_{p'}, \Gamma_{p'}, \psi_{p'}, s_{p'})$ of p and p' with a group isomorphism $\rho_p : \Gamma_p \rightarrow \Gamma_{p'}$, a ρ_p -equivariant diffeomorphism $\phi_p : V_p \rightarrow V_{p'}$ and a ρ_p -equivariant bundle isomorphism $\widehat{\phi}_p$ which covers ϕ_p . They are required to satisfy $s_{p'} \circ \phi_p = \widehat{\phi}_p \circ s_p$ and $\psi_{p'} \circ \phi_p = \phi \circ \psi_p$ for an induced homeomorphism $\phi_p : s_p^{-1}(0)/\Gamma_p \rightarrow s_{p'}^{-1}(0)/\Gamma_{p'}$ from ϕ_p .

These data should be compatible with the coordinate changes of Kuranishi structure as in [25, A1.47].

We write $((\rho_p, \phi_p, \widehat{\phi}_p), \phi)$ for an automorphism of Kuranishi structure. An automorphism $((\rho_p, \phi_p, \widehat{\phi}_p), \phi)$ is said to be conjugate to $((\rho'_p, \phi'_p, \widehat{\phi}'_p), \phi')$ if $\phi = \phi'$ and if there exists $\gamma_p \in \Gamma_{\psi(p)}$ for each p satisfying

$$\rho'_p = \gamma_p \cdot \rho_p \cdot \gamma_p^{-1}, \quad \phi'_p = \gamma_p \cdot \phi_p, \quad \widehat{\phi}'_p = \gamma_p \cdot \widehat{\phi}_p.$$

Definition 9.6. Consider an action of a finite group G on X and suppose X is compact. It is called an action on a space with Kuranishi structure if each $g \in G$ -action from X to itself lifts to an automorphism ϕ_* of the Kuranishi structure, and the composition g_* and h_* is conjugate to $(gh)_*$.

The following lemma of [25] is essential in our application.

Lemma 9.7. [25, A1.49] *If a finite group G acts on a space X with Kuranishi structure, then the quotient space X/G has a Kuranishi structure.*

If X has a tangent bundle and the action preserves it, then the quotient space has a tangent bundle. If X is oriented and the action preserves the orientation, then the quotient space has an orientation.

Proof. We only give a brief sketch, here. Let $g \in G$ and $p \in X$. We put $G_p = \{g \in G \mid g \cdot p = p\}$. Take a Kuranishi neighborhood of p

$$(V_p, E_p, \Gamma_p, \psi_p, s_p)$$

such that V_p is G_p -invariant. We want to extend Γ_p using G_p to obtain another finite group $\Gamma_{[p]}$ which acts on V_p . Then, $\Gamma_{[p]}$ will serve as a local group for a Kuranishi neighborhood of $[p]$ in X/G . We assume that the G_p -action on V_p is effective, and otherwise, it can be made effective by adding a finite dimensional representation to V_p and E_p .

Both G_p and Γ_p can be considered as a subgroup of the group of diffeomorphisms of V_p . The extension $\Gamma_{[p]}$ is the group generated by these two subgroups G_p, Γ_p in $Diff(V_p)$. From Definition 9.6, there exist $\gamma_{g_1, g_2} \in \Gamma_p$ for g_1 and g_2 in G_p such that

$$g_1 \circ g_2 = \gamma_{g_1, g_2} \circ (g_1 g_2).$$

Also from Definition 9.5, we have

$$g \circ \gamma = \rho_{g, p}(\gamma) \circ g$$

for $g \in G_p$ and $\gamma \in \Gamma_p$. This implies that the extension group $\Gamma_{[p]}$ satisfies the following exact sequence

$$1 \rightarrow \Gamma_p \rightarrow \Gamma_{[p]} \rightarrow G_p \rightarrow 1.$$

The $\Gamma_{[p]}$ -action lifts to an action on $E_p \times V_p$, and $\psi_p : s_p^{-1}(0)/\Gamma_p \rightarrow X$ induces $\psi_{[p]} : s_p^{-1}(0)/\Gamma_{[p]} \rightarrow X/G$. Thus, we get a Kuranishi neighborhood $(V_p, E_p, \Gamma_{[p]}, \psi_{[p]}, s_p)$ of $[p] \in X/G$. □

This lemma will be used to find a compatible good coordinate system and equivariant sections thereof.

First, let us consider a good coordinate system on X given by a partially ordered set (\mathfrak{P}, \leq) , which parametrizes a collection of Kuranishi neighborhoods covering X . (Technically, we require that this system additionally satisfy properties in [28, Definition 5.3].) Namely, given $\mathfrak{p} \in \mathfrak{P}$ we have a corresponding Kuranishi neighborhood $(V_{\mathfrak{p}}, E_{\mathfrak{p}}, \Gamma_{\mathfrak{p}}, \psi_{\mathfrak{p}}, s_{\mathfrak{p}})$, and partial order describes directions of embeddings.

We say that a good coordinate system on X is compatible with the G -action on X if the following holds:

- 1) For $\mathfrak{p} \in \mathfrak{P}$ and $g \in G$, there exist $\mathfrak{p}' \in \mathfrak{P}$ such that g_* sends the Kuranishi neighborhood for \mathfrak{p} to that of \mathfrak{p}' (this defines a map $g_* : \mathfrak{P} \rightarrow \mathfrak{P}$ such that $\mathfrak{p}' = g_*(\mathfrak{p})$);
- 2) The map g_* preserves the partial order of \mathfrak{P} .

We owe the following lemma to Kenji Fukaya.

Lemma 9.8. *Let X be a space with Kuranishi structure together with a G -action on it. Then, there exist a good coordinate system compatible with the G -action on X .*

Proof. A good coordinate system is chosen by the induction on the dimension of V_p and by gluing several Kuranishi neighborhoods (in order to get a bigger one satisfying desired properties). From the previous lemma, X/G is also a space with Kuranishi structure, and hence admits a good coordinate system. Then, we glue the corresponding charts in X in the same way we construct the good coordinate system for X/G . This produces a desired good coordinate system on X which is compatible with the G -action. \square

We now explain how to choose multi-sections. If Ψ is an automorphism of a space with Kuranishi structure Ψ and s is a multi-section, then we can pull back s by Ψ in an obvious way. Write the pulled-back multi-section by Ψ^*s .

Definition 9.9. A multisection s is said to be G -equivariant if for each $g \in G$ the corresponding automorphism of Kuranishi structure g_* sends s to itself.

If a multisection s is G -equivariant, the zero set of s admits the obvious G -action. Equivariant multi-sections can be constructed from a multi-section for X/G . Virtual fundamental chains obtained in this way admit natural G -actions, and evaluation maps become G -equivariant as well.

Lemma 9.10. *Let X be a space with Kuranishi structure equipped with G -action and fix a G -compatible good coordinate system. Then the family of multisection $\{s'_{p,\epsilon}\}$ in Lemma 9.4 can be chosen to be G -equivariant.*

Proof. This is again done by choosing a multi-section for X/G first. We examine how to do it in local charts. Let $(V_p, E_p, \Gamma_{[p]}, \psi_{[p]}, s_p)$ be a Kuranishi neighborhood for $[p] \in X/G$. Given a multi-section $s_{p',\epsilon} : V_p \rightarrow \mathcal{S}^n(E_p)$ (which is $\Gamma_{[p]}$ -equivariant by definition), the same multi-section $s_{p',\epsilon}$ can be regarded as a multi-section for the Kuranishi neighborhood $(V_p, E_p, \Gamma_p, \psi_p, s_p)$ of $p \in X$ since it is Γ_p -equivariant also. The $\Gamma_{[p]}$ -equivariance implies that the multi-section $s_{p',\epsilon}$ is G_p -equivariant. \square

We finally deal with transversality of evaluation maps from moduli spaces. We want to choose multi-sections suitably so that evaluation maps become submersive. Fukaya, Oh, Ohta and Ono [27] defined Lagrangian Floer theory on de Rham model using continuous families of multi-sections, and constructed smooth correspondences using such gadgets. It is straightforward to modify the construction of smooth correspondences by using a continuous family of multi-sections which fits into our G -equivariant setting. Let us illustrate it for the local chart, and leave details to the reader.

Consider a chart $(V_p, E_p, \Gamma_p, \psi_p, s_p)$ from Lemma 9.7 with $\Gamma_{[p]}$ as before. Let $f_p : V_p \rightarrow M$ be a submersion. A vector space W_p is chosen to have sufficiently large dimension so that there exists a surjective bundle map $Sur : W_p \times V_p \rightarrow E_p$. The extended space W_p is given the trivial $\Gamma_{[p]}$ -action. We put

$$\mathfrak{s}_p^{(1)}(w, x) = Sur(w, x) + s_p(x).$$

It is no longer $\Gamma_{[p]}$ -equivariant, so we take (family of) multi-sections

$$(9.1) \quad \mathfrak{s}_p(w, x) := \mathfrak{s}_p^{(2)}(w, x) = [\gamma_1 \mathfrak{s}_p^{(1)}(w, x), \dots, \gamma_g \mathfrak{s}_p^{(1)}(w, x)]$$

where $\Gamma_{[p]} = \{\gamma_1, \dots, \gamma_g\}$. Then, \mathfrak{s}_p is transversal to 0 and the restriction of $f_p \circ \pi_p : W_p \times V_p \rightarrow M$ to $\cup_i \{(w, x) \mid \mathfrak{s}_{p,i}(w, x) = 0\}$ is a submersion. For $g \notin G_p$, we can choose $W_p = W_{g(p)}$ and make the related construction done in g -equivariant way.

Recall from [27] that smooth correspondence is defined locally as follows. Let θ_p be a compactly supported smooth differential form on V_p , which is Γ_p -invariant. We put smooth measure ω_p on W_p so that $\int_{W_p} \omega_p = 1$. (For $g \notin G_p$, we take $\omega_{gp} = (g^{-1})^* \omega_p$.)

Definition 9.11. We define

$$(9.2) \quad \begin{aligned} & ((V_p, E_p, \Gamma_p, \psi_p, s_p), (W_p, \omega_p), \mathfrak{s}_p, f_p)_* (\theta_p) \\ & := \frac{1}{|\Gamma_p|} \sum_{j=1}^l \frac{1}{l} \left(f_p \circ \pi_p|_{\mathfrak{s}_{p,j}^{-1}(0)} \right)_! (\pi_p^* \theta_p \wedge \omega_p)|_{\mathfrak{s}_{p,j}^{-1}(0)} \end{aligned}$$

where l is the number of branches of \mathfrak{s}_p . This is a G_p -equivariant map.

We can put various W_p 's compatibly in the good coordinate system by using almost the same technique as in [27].

10. Group actions on A_∞ -algebra of a Lagrangian submanifold

Let L be a (relatively) spin Lagrangian submanifold in a symplectic manifold (M, ω) . The Floer cochain complex between L and itself has a structure of an A_∞ -algebra as observed in [25]. If the finite group G acts on M and preserves L , then we can construct a group action on the A_∞ -algebra of L which is compatible with A_∞ -operations. The construction does not involve spin profiles and G -Novikov theory. We only need equivariant transversality in the previous section with a little bit of algebraic manipulation. We will mainly discuss the latter in this section.

The actual construction of A_∞ -algebra involves a long sequence of technical constructions. We do not reproduce the whole steps here, but only indicate how to adapt constructions in [25] in our setting, omitting most of the steps which can be done by straightforward modification of theirs. We remark that the (m_1) -cohomology of the A_∞ -algebra is the Floer cohomology $HF(L, L)$, and in particular, spin profiles automatically match. This provides a explanation on why the spin profile condition is not necessary in this case. Moreover, we do not have to reduce the G -action to the action of the energy zero subgroup G_α . The reason behind it will be discussed in Section 11.

Suppose that a finite group G acts on M effectively, preserving the symplectic form ω , almost complex structure J , a spin Lagrangian submanifold L and its isomorphism class of spin structure. Hence, G acts on the moduli spaces of stable J -holomorphic discs bounding L , and the local Kuranishi model for a stable map is identical under group action.

As long as two spin structures $(A_{g-1})^* P_{spin}(L)$ and $P_{spin}(L)$ are isomorphic, the induced orientations on the moduli spaces of discs are the same, and the choice of the particular isomorphism A_g^{spin} do *not* play a role, here.

Thus, the following proposition follows from the construction of [25] and G -Kuranishi structure built in the previous section. Let $\beta \in H_2(M, L; \mathbb{Z})$, and $k \geq 1$.

Proposition 10.1. [25, Theorem 2.1.29] *The moduli space $\mathcal{M}_{k,l}^{main}(L, J, \beta)$ of stable J -holomorphic discs with boundary on L with k boundary marked points (cyclically ordered) and l interior marked points has a Kuranishi structure with an action of G in the sense of Definition 9.6. We can choose family of G -equivariant multisections \mathfrak{s} for which the moduli space has a virtual fundamental chain of dimension $m + \mu_L(\beta) + k + 2l - 3$.*

Let $\Phi_{\beta,k} := (ev_0, \dots, ev_k) : \mathcal{M}_{k+1}(L, \beta) \mapsto (L)^{\times(k+1)}$ be the boundary evaluation map. Then, the g -action induces an isomorphism $(A_g)_* : \mathcal{M}_{k+1}(L, \beta) \rightarrow \mathcal{M}_{k+1}(L, \beta)$ with commuting diagram

$$(10.1) \quad \begin{array}{ccc} \mathcal{M}_{k+1}(L, \beta) & \xrightarrow{\Phi_{\beta,k}} & L \times \cdots \times L \\ (A_g)_* \downarrow & & \downarrow A_g \\ \mathcal{M}_{k+1}(L, \beta) & \xrightarrow{\Phi_{\beta,k}} & L \times \cdots \times L \end{array}$$

where A_g in the right column is the diagonal action of g .

For convenience, we work on the de Rham model of an A_∞ -algebra, whose construction is described in [27]. A de Rham model A_∞ -algebra has been extensively used in the toric setting recently, where Lagrangian submanifolds are T^n -orbits. T^n -equivariant evaluation maps are automatically submersive, and hence was directly used to define the push-forward of differential forms.

Consider the de Rham complex $\Omega(L)$ of L . A multi-linear map

$$m_{k,\beta} : \overbrace{\Omega(L) \otimes \cdots \otimes \Omega(L)}^k \rightarrow \Omega(L)$$

is defined as follows:

$$m_{k,\beta}(\rho_1, \dots, \rho_k) = (ev_0)_!(ev_1, \dots, ev_k)^*(\rho_1, \dots, \rho_k).$$

where $(ev_0)_!$ is an integration along fibers if ev_0 is a submersion. In general, it is the G -equivariant smooth correspondence described in the previous

section. (See the diagram below.)

$$(10.2) \quad L \xleftarrow{ev_0} \mathcal{M}_{k+1}^{main}(L; \beta)^s \xrightarrow{\Phi_{\beta, k}} \overbrace{L \times \cdots \times L}^k$$

We put

$$m_k = \sum_{\beta} T^{\omega(\beta)} m_{k, \beta} \quad (\text{for } k \neq 1),$$

$$m_1(\rho_1) = (-1)^{\deg \rho_1 + n + 1} d\rho_1 + \sum_{\beta} T^{\omega(\beta)} m_{1, \beta}(\rho_1).$$

As shown in [27], $\{m_k\}_{k \geq 0}$ defines an A_∞ -structure on $\Omega(L)$. i.e. the family of operations satisfying

$$(10.3) \quad \sum_{k_1+k_2=k+1} \sum_i (-1)^* m_{k_1}(\rho_1, \dots, m_{k_2}(\rho_i, \dots, \rho_{i+k_2-1}), \dots, \rho_k) = 0$$

where $*$ = $|\rho_1| + \cdots + |\rho_{i-1}| + i - 1$.

Note that if E and M are manifolds with G -actions, and if $f : E \rightarrow M$ is a G -equivariant submersion, then the integration along fiber $f_!$ is well-defined on the cochain level, and is G -equivariant. Therefore, we obtain the following lemma.

Lemma 10.2. *The operations $\{m_k\}$ are G -equivariant in the sense that*

$$(10.4) \quad m_{k, \beta}(g \cdot \rho_1, \dots, g \cdot \rho_k) = g \cdot m_{k, \beta}(\rho_1, \dots, \rho_k).$$

where $g \cdot \rho = (g^{-1})^* \rho$

Due to the problem “running out of Kuranishi neighborhood” [25, Section 7.2], one first construct a G -equivariant A_N -algebra of the Lagrangian submanifold L for a large N . Then, the desired A_∞ -algebra is obtained by further applying algebraic formalism as follows. (See [25, Theorem 7.2.27] for more details.)

In what follows, we will use the (tensor) coalgebra language which much reduces the notational complexity. m_k gives rise to the coderivation \hat{m}_k , and $\hat{d} := \sum_{k=0}^\infty \hat{m}_k$ on the tensor coalgebra $T\Omega(L)$. We write $\mathbf{x} = x_1 \otimes \cdots \otimes x_k$, and $g(\mathbf{x}) = g(x_1) \otimes \cdots \otimes g(x_k)$. An A_∞ -homomorphism f induces a cohomomorphism \hat{f} between coalgebras. One can average an A_∞ -homomorphism to make it G -equivariant in the following way.

Lemma 10.3. *Let $\mathfrak{f} = \{f_i\}$ be an A_∞ homomorphism between two A_∞ algebras C_1 and C_2 with G -actions. The average $\hat{\mathfrak{f}}_{avg}$ is defined by*

$$\hat{\mathfrak{f}}_{avg}(\mathbf{x}) := \frac{1}{|G|} \sum_g g\hat{\mathfrak{f}}(g^{-1}\mathbf{x}).$$

Then, $\hat{\mathfrak{f}}_{avg}$ gives a G -equivariant A_∞ homomorphism.

Proof. $\hat{\mathfrak{f}}_{avg}$ is G -equivariant by construction. We need to prove that $\hat{\mathfrak{f}}_{avg} \circ \hat{d} = \hat{d} \circ \hat{\mathfrak{f}}_{avg}$. From (10.4), \hat{d} commutes with the g -action. Also, \hat{d} commutes with $\hat{\mathfrak{f}}$ since f is an A_∞ -homomorphism. Hence, the lemma follows. \square

Remark 10.4. Averaging of A_∞ -operations of a non- G -equivariant A_∞ -algebra does not produce an A_∞ -algebra.

The lemma below follows immediately.

Lemma 10.5. *$(\hat{\mathfrak{h}} \circ \hat{\mathfrak{f}})_{avg} = \hat{\mathfrak{h}}_{avg} \circ \hat{\mathfrak{f}}$ and $(\hat{\mathfrak{f}} \circ \hat{\mathfrak{h}})_{avg} = \hat{\mathfrak{f}} \circ \hat{\mathfrak{h}}_{avg}$ provided that \mathfrak{f} is G -equivariant (i.e. $\hat{\mathfrak{f}}_{avg} = \hat{\mathfrak{f}}$).*

We introduce the notion of A_∞ -homotopies in the existence of the group action. Let $(C[1], \{m_k\})$ be an A_∞ -algebra over R on which a finite group G acts and suppose that each m_k is G -equivariant. ([1] means the degree shifting.) The A_∞ -homotopy is defined by employing a model of $C \times [0, 1]$. When $R \supset \mathbb{R}$, the A_∞ -algebra $C[1] \otimes R[t, dt]$ can be used as a model. (See [22, Definition 8.37] or [25, Definition 4.29, Lemma 4.2.13] for extended A_∞ -operations on $C[1] \otimes R[t, dt]$.) A G -action on $C[1] \otimes R[t, dt]$ is defined by giving a trivial G -action on $R[t, dt]$ factor. i.e. the G -action on $C[1] \otimes R[t, dt]$ is $R[t, dt]$ -linear. It is easy to see that A_∞ operations on $C[1] \otimes R[t, dt]$ are G -equivariant.

Recall that we have an A_∞ homomorphism $\text{Eval}_{t=t_0} : C[1] \otimes R[t, dt] \rightarrow C[1]$ given by

$$\text{Eval}_{t=t_0}(P(t) + Q(t)dt) = P(t_0).$$

All other higher components of $\text{Eval}_{t=t_0}$ are defined to be zero. $\text{Eval}_{t=t_0}$ is obviously G -equivariant and so is $\hat{\text{Eval}}_{t=t_0}$.

Definition 10.6. Two (G -equivariant) A_∞ homomorphisms $\phi, \phi' : C \rightarrow C'$ are said to be (G -)homotopic to each other, if there exists a (G -equivariant) A_∞ homomorphism $H : C \rightarrow C' \otimes R[t, dt]$ such that $\text{Eval}_{t=0} \circ H = \phi$ and $\text{Eval}_{t=1} \circ H = \phi'$.

Lemma 10.7. *Suppose that C and C' are both equipped with G -equivariant A_∞ structures and $\phi : C \rightarrow C'$ is G -equivariant. If ϕ and ϕ' are homotopic, then so are ϕ and ϕ'_{avg} . Moreover, one can take a G -equivariant homotopy between ϕ and ϕ'_{avg} .*

Proof. Let H be a homotopy between ϕ and ϕ' . Then, by taking “hat” and averaging the equations $\text{Eval}_{t=0} \circ H = \phi$ and $\text{Eval}_{t=1} \circ H = \phi'$, we get

$$\widehat{\text{Eval}}_{t=0} \circ \widehat{H}_{avg} = \widehat{\phi} \quad \widehat{\text{Eval}}_{t=1} \circ \widehat{H}_{avg} = \widehat{\phi}'_{avg}.$$

□

We are now ready to state the G -equivariant version of the A_∞ -Whitehead theorem.

Theorem 10.8. *Let $\mathfrak{f} : C_1 \rightarrow C_2$ be a G -equivariant weak homotopy equivalence between two filtered A_∞ algebras C_1 and C_2 with G -actions. Then, there exists a quasi-inverse $\mathfrak{h} : C_2 \rightarrow C_1$ of \mathfrak{f} which is also G -equivariant.*

Proof. Usual Whitehead theorem for A_∞ -algebras in [25] produces a quasi-inverse $\tilde{\mathfrak{h}}$ of \mathfrak{f} . By averaging \mathfrak{h} as in Definition 10.3, we obtain the A_∞ homomorphism \mathfrak{h}_{avg} which is G -equivariant. Since \mathfrak{f} is G -equivariant, we may apply Lemma 10.5 so that $(\hat{\mathfrak{h}} \circ \hat{\mathfrak{f}})_{avg} = \hat{\mathfrak{h}}_{avg} \circ \hat{\mathfrak{f}}$ and $(\hat{\mathfrak{f}} \circ \hat{\mathfrak{h}})_{avg} = \hat{\mathfrak{f}} \circ \hat{\mathfrak{h}}_{avg}$. Note that $\hat{id}_{avg} = \hat{id}$. Then, by Lemma 10.7, we get G -equivariant homotopies

$$\hat{\mathfrak{h}}_{avg} \circ \hat{\mathfrak{f}} \simeq \hat{id}_{C_1}, \quad \hat{\mathfrak{f}} \circ \hat{\mathfrak{h}}_{avg} \simeq \hat{id}_{C_2}.$$

□

In order to construct A_∞ -algebra from A_N (or $A_{n,K}$ -algebra in the filtered case) the following theorem is essential.

Theorem 10.9. *(c.f. [25, Theorem 7.2.72]) Let C_1 be a filtered $A_{n,K}$ algebra and C_2 a filtered $A_{n',K'}$ algebra with $(n, K) < (n', K')$, both of which are assumed to be G -equivariant. Let $\mathfrak{h} : C_1 \rightarrow C_2$ be a G -equivariant filtered $A_{n,K}$ homomorphism which gives rise to a filtered $A_{n,K}$ homotopy equivalence.*

Then, there exist a G -equivariant filtered $A_{n',K'}$ algebra structure on C_1 extending the given $A_{n,K}$ algebra structure and a G -equivariant filtered

$A_{n',K'}$ homotopy equivalence $C_1 \rightarrow C_2$ extending the given filtered $A_{n,K}$ homotopy equivalence \mathfrak{h} .

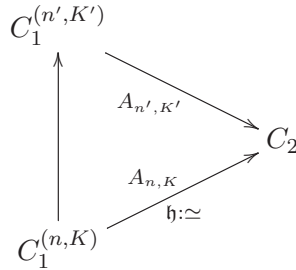

Proof. We just mention how to modify the original proof of [25], which deals with the obstruction class of extending $A_{n,K}$ structure to the next level. Its G -equivariant version will be explained only for the unfiltered case for simplicity. Given an A_N structure with $\{m_k\}_{k=1}^N$, the subsequent operation m_{N+1} should be defined to satisfy the next A_∞ -equation

$$\begin{aligned}
 (10.5) \quad m_1 \circ m_{N+1}(\mathbf{x}) + m_{N+1} \circ m_1(\mathbf{x}) \\
 + \sum_{k_1+k_2=N+1} (-1)^{\deg' \mathbf{x}_1} m_{k_1}(\mathbf{x}_1, m_{k_2}(\mathbf{x}_2), \mathbf{x}_3) = 0.
 \end{aligned}$$

Denote the last term of (10.5) by o_{N+1} . One can easily check that o_{N+1} is a δ -cocycle in the cochain complex

$$(Hom(B_N C[1], C[1]), \delta = [m_1, \cdot]).$$

Thus, it precisely gives the obstruction class for the desired extension. In addition, if A_N algebra is G -equivariant, o_{N+1} defines a G -equivariant map from $B_N C[1]$ to $C[1]$, and hence lies in the subcomplex $(Hom_G(B_N C[1], C[1]), \delta)$.

Note that G -equivariant A_N homotopy equivalence \mathfrak{h} preserve the obstruction class $[o_{N+1}]$, and that the obstruction vanishes if the target of \mathfrak{h} has a G -equivariant $A_{N'}$ structure with $N' > N$. Therefore, we can choose a G -equivariant m_{N+1} which satisfies (10.5) for C_1 . In a similar manner, the original construction of [25] can be modified to include the G -equivariance as above. \square

Following the rest of [27], we obtain

Theorem 10.10. *There exist a G -equivariant A_∞ -algebra $\Omega(L) \widehat{\otimes} \Lambda_{nov}$ of a spin Lagrangian submanifold L , and its G -invariant part again becomes an A_∞ -algebra, which will be called the A_∞ -algebra of $[L/G]$ in $[M/G]$.*

The G -equivariance implies that If ρ_1, \dots, ρ_k are all G -invariant, then so is $m_{k,\beta}(\rho_1, \dots, \rho_k)$. Therefore, we obtain an operation

$$m_{k,\beta} : \overbrace{\Omega(L)^G \otimes \dots \otimes \Omega(L)^G}^k \rightarrow \Omega(L)^G$$

simply by restricting $m_{k,\beta}$ to the set of G -invariant differential forms on L . This gives rise to a well-defined A_∞ -structure on $\Omega(L)^G$.

Within this setting, we may define G -bounding cochain as a bounding cochain which is G -invariant. G -bounding cochains define boundary deformations of A_∞ -algebra of $[L/G]$.

Remark 10.11. The average of a bounding cochain does not become a G -bounding cochain.

The A_∞ -algebra of $[L/G]$ constructed here is only concerned with smooth J -holomorphic discs with boundary on L . In order to obtain richer orbifold theory, one should additionally consider orbi-discs or bulk deformations by twisted sectors, which are introduced by the first author and Poddar [18] in the case of toric orbifolds.

11. G -equivariant A_∞ -bimodule $CF_{R,l_0}^*(L_0, L_1)$

We consider equivariant A_∞ -bimodules and consider Lagrangian Floer homology of a pair. We first review the A_∞ -bimodule structure briefly. Recall that a boundary operator $\delta : CF_{R,l_0}^*(L_0, L_1) \rightarrow CF_{R,l_0}^*(L_0, L_1)$ was defined in [25] by

$$(11.1) \quad \delta([w, l_p]) = \sum_{\mu([w', l_q]) - \mu([w, l_p]) = 1} \# \mathcal{M}(L_1, L_0; [w, l_p], [w', l_q]) [w', l_q].$$

Here, $\mathcal{M}(L_1, L_0; [w, l_p], [w', l_q])$ is the moduli space of J -holomorphic strips u such that $[w \star u, l_q] = [w', l_q]$. The orientations of these moduli spaces are already well-studied by [25].

Theorem 11.1. *[25, 8.1.14] Suppose that a pair of Lagrangian submanifolds (L_0, L_1) is (relatively) spin. Then for any $p, q \in L_0 \cap L_1$, the moduli*

space $\mathcal{M}(L_1, L_0; [w, l_p], [w', l_q])$ of connecting orbits in Lagrangian intersection Floer cohomology is orientable. Furthermore, orientations on $\Theta_{[w, l_p]}^-$ and $\Theta_{[w', l_q]}^-$ and related spin structures canonically determine the orientation on $\mathcal{M}(p, q)$.

In general, disc bubbling phenomenon produce non-trivial m_0 term, and hence $\delta^2 \neq 0$. The general algebraic structure one obtains is in fact A_∞ -bimodule over A_∞ -algebras of L_0 and L_1 . Recall that A_∞ -bimodule M over A_∞ -algebras C_1, C_2 are given by sequence of maps

$$\{n_{k_1, k_2} : B_{k_1} C_1 \otimes M \otimes B_{k_2} C_2 \rightarrow M\}_{k_1, k_2 \geq 0},$$

satisfying an A_∞ -bimodule equation. Such an A_∞ -bimodule is called G -equivariant, if G acts on M and C_i linearly and each n_{k_1, k_2} satisfies

$$\begin{aligned} &g \cdot n_{k_1, k_2}(a_1, \dots, a_{k_1}, \xi, b_1, \dots, b_{k_2}) \\ &= n_{k_1, k_2}(g \cdot a_1, \dots, g \cdot a_{k_1}, g \cdot \xi, g \cdot b_1, \dots, g \cdot b_{k_2}). \end{aligned}$$

Now, suppose L_0 and L_1 admit G -actions inherited from the one on the ambient symplectic manifold. Assume further that the spin structures on L_0 and L_i are G -invariant. i.e. they are isomorphic to their pull-back under any element of G . Then, the spin bundle on L_i gives a spin profile $s_i \in H^2(G; \mathbb{Z}/2)$ for $i = 0, 1$. Assume $s_0 = s_1$.

Remark 11.2. Since we will only consider the action of the energy zero subgroup G_α of G for L_0 and L_1 , the condition $s_0 = s_1$ can be weakened to the agreement of s_0 and s_1 when restricted to $H^2(G_\alpha; \mathbb{Z}/2)$.

As studied in Section 9, the union of all moduli spaces $\mathcal{M}(L_1, L_0; [w, l_p], [w', l_q])$ with a fixed symplectic energy, has a Kuranishi structure with a G_α -action. Therefore, $\delta = n_{0,0}$ is G_α -equivariant and the homology of $(CF_{R, l_0}^*(L_0, L_1), \delta)$ admits a natural G_α -action if $\delta^2 = 0$.

Definition 11.3. With the setting as above, the G_α -invariant part of the homology is called the Lagrangian Floer cohomology of the pair $([L_0/G], [L_1/G]; l_0)$ and will be written by

$$HF_{R, l_0}^*([L_0/G], [L_1/G]).$$

We take the sum over all possible l_0 to define Lagrangian Floer cohomology of the pair $([L_0/G], [L_1/G])$.

Remark 11.4. If $G \neq G_\alpha$, we introduced orbifold Novikov ring Λ_{nov}^{orb} in Subsection 8.3, and explained that Λ_{nov}^{orb} is not visible if we use the universal Novikov field.

As in the previous section, it is not hard to adapt the construction of [25] (or [27] for the de Rham version) to define G_α -equivariant A_∞ -bimodules for the pair (L_0, L_1) . Again using equivariant Kuranishi perturbations, and adapting the construction of [25] as in the previous section, one can prove

Proposition 11.5. *We have a G_α -equivariant filtered A_∞ -bimodule $(CF_{R,l_0}^*(L_0, L_1), \{n_{k_1, k_2}\})$ with $n_{0,0} = \delta$ over G_α -equivariant A_∞ -algebras of L_0 and L_1 .*

Now, let us consider the case that L_1 is obtained by Hamiltonian diffeomorphism of L_0 , i.e. $L_1 = \phi_H^1(L_0)$ for a time-dependent G -invariant Hamiltonian H . We remark that if H is not G -invariant, the corresponding Hamiltonian perturbation together with the group action produces possibly as many as $|G|$ -copies of Hamiltonian perturbations of L_0 , which can be considered as a G -equivariant immersion of Lagrangian submanifolds. We plan to study such general cases in [14].

Here, we only consider G -invariant $H : M \times [0, 1] \rightarrow \mathbb{R}$ such that each H_t for $t \in [0, 1]$ is a G -invariant function. This implies that ϕ_H^1 is G -equivariant, and hence, for example, g -fixed points of M can only move to a g -fixed points by ϕ_H^1 . $\phi_H^1(L_0)$ is, then, preserved by G . Since L_0 and $\phi_H^1(L_0)$ are equivariantly isotopic, one can identify their spin bundles and liftings of G -actions on spin bundles. Thus, spin profiles of L_0 and $\phi_H^1(L_0)$ coincide.

The energy zero subgroup $G_\alpha \subset G$ for the pair $(L_0, \phi_H^1(L_0))$ is particularly simple. Indeed, we will show that G_α becomes the entire group G . We first choose a candidate for energy zero path for each $g \in G$ as follows.

If we define $\tilde{H} : M \rightarrow \mathbb{R}$ by

$$\tilde{H}(x) = \int_{0 \leq t \leq 1} (\phi_H^t)^* H_t(x) dt = \int_{0 \leq t \leq 1} H_t(\phi_H^t(x)) dt,$$

then \tilde{H} is also G -invariant (since ϕ_H^t is G -equivariant.) Fix a generic point x_0 in L_0 and choose for each $g \in G$ a path γ_g in L_0 from x_0 to $g \cdot x_0$. We take a base path l_0 from L_0 to $\phi_H^1(L_0)$ to be $l_0(t) := \phi_H^t(x_0)$. Then, the strip $w_g : [0, 1]^2 \rightarrow M$ defined by

$$w_g(t, s) = \phi_H^t(\gamma_g(s))$$

gives a path from l_0 to $g(l_0)$ in $\Omega(L_0, \phi_H^1(L_0); l_0)$. We claim that this path has zero energy.

Lemma 11.6. *w_g is an energy zero path.*

Proof. We have to show that $\int_{w_g} \omega = \int_{[0,1]^2} w_g^* \omega = 0$. Observe that

$$\begin{aligned} w_g^* \omega \Big|_{(t,s)} \left(\frac{\partial}{\partial t}, \frac{\partial}{\partial s} \right) &= \omega \left((X_{H_t})_{\phi_H^t(\gamma_g(s))}, (\phi_H^t)^* \gamma'_g(s) \right) \\ &= dH_t \left((\phi_H^t)^* \gamma'_g(s) \right)_{\phi_H^t(\gamma_g(s))} \\ &= d \left((\phi_H^t)^* H_t \right) (\gamma'_g(s))_{\gamma_g(s)} \\ &= \frac{d}{ds} \left((\phi_H^t)^* H_t \right) (\gamma_g(s)) \end{aligned}$$

Therefore, the energy of w_g is given by

$$\begin{aligned} \mathcal{A}(w_g) &= \int_{0 \leq s \leq 1} \int_{0 \leq t \leq 1} \left(\frac{d}{ds} \left((\phi_H^t)^* H_t \right) (\gamma_g(s)) \right) dt ds \\ &= \int_{0 \leq s \leq 1} \frac{d}{ds} \left(\int_{0 \leq t \leq 1} (\phi_H^t)^* H_t (\gamma_g(s)) dt \right) ds \\ &= \int_{0 \leq s \leq 1} \frac{d}{ds} \left(\tilde{H}(\gamma_g(s)) \right) ds \\ &= \tilde{H}(\gamma_g(1)) - \tilde{H}(\gamma_g(0)) = 0 \end{aligned}$$

since \tilde{H} is G -invariant and $\gamma_g(1) = g \cdot \gamma_g(0)$. □

It directly follows from the lemma that

Corollary 11.7. *With the setting as above, the energy zero subgroup for a pair $(L_0, \phi_H^1(L_0))$ is the entire group G .*

Recall that the A_∞ -algebra is a bimodule over itself. So we can compare two A_∞ -bimodules $\Omega(L_0)$ and $CF_{R,l_0}^*(L_0, L_1)$ over A_∞ algebra of L_0 . The following proposition of [25] can be also proved in a G -equivariant setting along the same line of their proof, and we omit the details.

Proposition 11.8. *Suppose that L_0 is connected and let $L_1 = \phi_H^1(L_0)$ as above. Then there is a G -equivariant filtered A_∞ -bimodule quasi-isomorphism*

$$(11.2) \quad \Omega(L_0) \hat{\otimes} \Lambda_{nov} \rightarrow CF_{R,l_0}^*(L_0, L_1) \otimes_{\Lambda(L, L_1; l_0)} \Lambda_{nov}.$$

In particular, if the G -invariant A_∞ -algebra of L_0 has a non-vanishing homology, L_0 and $\phi_H^1(L_0)$ have a non-trivial intersection for any time-dependent G -invariant Hamiltonian isotopy ϕ_H . One can further construct bulk-deformed (via twisted sectors) Lagrangian Floer theory of an orbifold Lagrangian to capture additional intersection results.

We remark that Seidel already observed in $\mathbb{Z}/2$ -action of exact case that such a Lagrangian Piunikhin-Salamon-Schwarz morphism exists and becomes an isomorphism, as well as Hamiltonian invariance of equivariant Lagrangian Floer homology. (see the last paragraph of section (14b) of [37]).

12. Equivariant flat vector bundles on G -invariant Lagrangians

In this section, we explain how to add G -equivariant flat vector bundles to the theory. In homological mirror symmetry, one needs to consider rank 1 flat unitary bundles on a Lagrangian submanifold. With a finite group action on the Lagrangian submanifold, it is natural to introduce G -equivariant structures on such line bundles. We also observe that we can define a natural action of a character group \hat{G} (which is the dual group G^* for abelian G) on both equivariant and orbifolded Fukaya categories by twisting G -equivariant structures on flat vector bundles. Such character group action comes into play in G -equivariant homological mirror symmetry, which will be studied in the next section. We remark that such character group action will be also discussed in our joint work with Siu-Cheong Lau in preparation.

We will assume that $G = G_\alpha$ for simplicity from now on. We first review the standard way of including these flat bundles into Lagrangian Floer theory (without group actions). For a unitary bundle U_i on a Lagrangian L_i ($i = 0, 1$), the new Floer complex $CF_{l_0}((L_0, U_0), (L_1, U_1))$ is defined by replacing each generator $[w, l_p]$ of $CF_{\mathbb{C}, l_0}^*(L_0, L_1)$ with $[w, l_p] \otimes \text{Hom}(U_0|_p, U_1|_p)$. The Floer differential δ in (11.1) is modified by additional contributions from holonomies. Namely, given $\lambda_p \in \text{Hom}(U_0|_p, U_1|_p)$ and a J -holomorphic strip u which maps $[w, l_p]$ to $[w \sharp u, l_q]$, we get $\lambda_q \in \text{Hom}(U_0|_q, U_1|_q)$ by composing λ_p with holonomies around two boundary components of u appropriately.

12.1. Equivariant structures

Consider a trivial complex vector bundle $L \times \mathbb{C}^n \rightarrow L$ of rank n where G acts on L . A G -equivariant structure on this bundle means the choice of a G -action on \mathbb{C}^n , or equivalently the choice of a representation $\theta : G \rightarrow$

$End(\mathbb{C}^n)$. Such a homomorphism induces the diagonal G -action on $L \times \mathbb{C}^n$. If $\chi : G \rightarrow U(1)$ is a character of G , then one can twist θ by χ and obtain $\theta^\chi : G \rightarrow End(\mathbb{C}^n)$ given by $\theta^\chi(g) = \chi(g)\theta(g)$.

In general, let $U \rightarrow L$ be a possibly non-trivial vector bundle on L . A G -equivariant structure on U is given by the choice of an isomorphism

$$(12.1) \quad \theta_g : U \xrightarrow{\cong} g^*U$$

for each $g \in G$, which satisfies the cocycle conditions.

Definition 12.1. The *twisting of a G -equivariant structure $\{\theta_g\}$* by a character $\chi : G \rightarrow U(1)$ is a G -equivariant structure $\{\theta_g^\chi\}$ on U defined by

$$(12.2) \quad \theta_g^\chi = \chi(g) \cdot \theta_g.$$

Here, $\chi(g) \cdot (-)$ is defined as a fiberwise complex multiplication on a complex vector bundle.

This defines a character group action on the set of G -equivariant structures on a vector bundle on L . Note that for an abelian group G , the set of G -equivariant structures on a complex trivial line bundle are in one-to-one correspondence with the dual group $G^* = \hat{G} = \text{Hom}(G, U(1))$.

Let L_0 and L_1 be two G -invariant Lagrangian submanifolds and choose G -equivariant flat complex vector bundles (U_0, θ^0) and (U_1, θ^1) on L_0 and L_1 , respectively. Here we allow U_i to have rank greater than 1 since an irreducible representation of G may have a dimension greater than 1. In particular, we expect that bundles of higher ranks might play a non-trivial role for non-abelian G .

We define the Floer cochain complex for the pair (L_0, U_0) and (L_1, U_1) similarly as above, but using orientation spaces.

$$(12.3) \quad CF((L_0, U_0), (L_1, U_1)) := \bigoplus_{[w, l_p]} |\Theta_{[w, l_p]}^-|_{\mathbb{C}} \otimes_{\mathbb{C}} \text{Hom}(U_0|_p, U_1|_p)$$

The Floer differential for (12.3) is defined in a standard way as explained above.

Definition 12.2. A G -action on (12.3) is defined as follows: for $g \in G$, a linear map

$$g : \text{Hom}(U_0|_p, U_1|_p) \rightarrow \text{Hom}(U_0|_{g \cdot p}, U_1|_{g \cdot p})$$

is given by $\phi \mapsto \theta_g^1(p) \circ \phi \circ \theta_{g^{-1}}^0(g \cdot p)$. The G -action on the first factor of (12.3) is exactly the same one as in Section 8.

Now, we consider G -invariant connections on a G -equivariant complex vector bundle (U, θ) on L :

Definition 12.3. A connection ∇ of a G -equivariant complex vector bundle (U, θ) on L is said to be G -invariant, if the pull-back connection $g^*\nabla$ is isomorphic to ∇ via θ_g . More precisely,

$$(12.4) \quad (\theta_g)_* (E_\nabla)_{(x,v)} = (E_\nabla)_{(g \cdot x, g \cdot v)}$$

where E_∇ is the horizontal distribution associated to ∇ .

We will only consider G -invariant connections from now on. Now, consider the pair (L_i, U_i) together with the choice of a G -invariant connection ∇_i on U_i for $i = 0, 1$.

Proposition 12.4. *The new Floer differential involving equivariant flat bundle data is G -equivariant.*

Proof. Let u be a holomorphic strip bounding L_0 and L_1 and let p and q be its end points. We denote by γ_i the boundary component of u lying in L_i . (See Figure 9.)

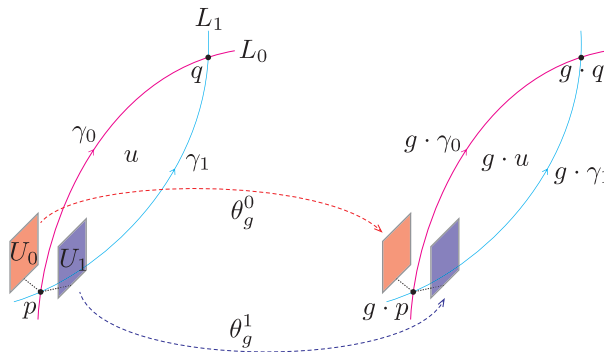

Figure 9: Group actions on line bundles and the Floer differential.

Take an element ϕ_p of $\text{Hom}(U_0|_p, U_1|_p)$ and g of G .

(i) We first compute $\delta \circ g : g$ sends ϕ_p to

$$\theta_g^1(p) \circ \phi_p \circ \theta_{g^{-1}}^0(g \cdot p) \in \text{Hom}(U_0|_{g \cdot p}, U_1|_{g \cdot p}),$$

and then, the strip $g \cdot u$ sends $\theta_g^1(p) \circ \phi_p \circ \theta_{g^{-1}}^0(g \cdot p)$ to

$$(12.5) \quad P_{g \cdot \gamma_1}^1 \circ (\theta_g^1(p) \circ \phi_p \circ \theta_{g^{-1}}^0(g \cdot p)) \circ (P_{g \cdot \gamma_0}^0)^{-1}$$

where P_γ^i means the parallel transport along γ by ∇_i for $i = 0, 1$.

(ii) Secondly, let us compute $g \circ \delta : u$ contributes to δ by sending ϕ_p to $P_{\gamma_1}^1 \circ \phi_p \circ (P_{\gamma_0}^0)^{-1}$. Now, applying the g -action, we get

$$(12.6) \quad \theta_g^1(q) \circ (P_{\gamma_1}^1 \circ \phi_p \circ (P_{\gamma_0}^0)^{-1}) \circ \theta_{g^{-1}}^0(g \cdot q).$$

We have to show that (12.5) and (12.6) represent the same element in $\text{Hom}(U_0|_{g \cdot q}, U_1|_{g \cdot q})$. This follows from the G -equivariance of ∇_i , which implies that the G -action on U_i commutes with the parallel transport for ∇_i . i.e.

$$P_{g \cdot \gamma_1}^1 \circ \theta_g^1(p) = \theta_g^1(q) \circ P_{\gamma_1}^1 \quad \text{and} \\ \theta_{g^{-1}}^0(g \cdot p) \circ (P_{g \cdot \gamma_0}^0)^{-1} = (P_{\gamma_0}^0)^{-1} \circ \theta_{g^{-1}}^0(g \cdot q).$$

□

Let λ be the action of \mathbb{C}^* on equivariant vector bundles defined by the fiberwise complex multiplication. Then, λ -action preserves connections in the sense that $\lambda^* \nabla = \nabla$. Note that the twisting by the character group is essentially given by the complex multiplication (12.2). Therefore, G -invariant connections still remain G -invariant after twisting equivariant structures on a bundle.

Remark 12.5. For an abelian G , one may use a homomorphism $h^{orb} : \pi_1^{orb}([L/G]) \rightarrow U(1)$ to classify equivariant flat line bundles on L and check the above discussion more rigorously. See the related explanation after Conjecture 14.5.

12.2. Equivariant Fukaya categories

We summarize the construction of equivariant Fukaya categories in this section, and also clarify once again the role of the group action and its

dual group action. We are considering the case that a finite group G effectively acts on a closed oriented symplectic manifold M . For each spin profile $s \in H^2(G, \mathbb{Z}/2)$, the equivariant Fukaya category $G\text{-}\mathcal{Fuk}^s(M)$ is defined as follows. An object of $G\text{-}\mathcal{Fuk}^s(M)$ is given by a G -invariant Lagrangian submanifold L whose spin profile equals s , together with a G -equivariant flat unitary bundle U . For each pair $(L_0, U_0), (L_1, U_1) \in \text{Ob}(G\text{-}\mathcal{Fuk}^s(M))$, we choose a reference path l_0 (one in each homotopy class) and we need to assume that energy zero subgroup G_α equals G always. Then, we define the morphism to be the (completed) direct sum over l_0 of the Floer complex of the pair $(L_0, U_0), (L_1, U_1)$ with respect to l_0 . There should be G -equivariant A_∞ -category operations by extending the construction in this paper to the one of Fukaya [23].

Remark 12.6. Note that we possibly have several equivariant Fukaya categories corresponding to spin profiles in $H^2(G, \mathbb{Z}/2)$, and each G -invariant (spin) Lagrangian submanifold L can belong to only one of them corresponding to its spin profile.

Remark 12.7. We may also consider α -twisted G -equivariant vector bundles for $\alpha \in H^2(G, U(1))$. These bundles are not G -equivariant, but their failures of G -cocycle conditions are given by α . We remark that there is a corresponding notion for sheaves, too (see for example [19]). In fact, from the expression (12.3), effects of $\alpha \in H^2(G, U(1))$ and a spin profile condition in $H^2(G, \mathbb{Z}/2)$ on Lagrangian Floer theory can be combined. Hence, it seems that we can enlarge the equivariant or the orbifolded fukaya category by including such objects. We leave it for future investigation.

As discussed, G acts on morphisms of the equivariant Fukaya category $G\text{-}\mathcal{Fuk}^s(M)$. By taking G -invariant part of morphisms of $G\text{-}\mathcal{Fuk}^s(M)$, we obtain the orbifolded Fukaya category $\mathcal{Fuk}_G^s(M)$, which still has an induced A_∞ -category structure. In fact, for the definition of orbifolded Fukaya category, we do not need assumptions that $G = G_\alpha$.

Now the character group \hat{G} acts on objects of $G\text{-}\mathcal{Fuk}^s(M)$ (hence also on morphisms), by twisting equivariant structures of G -bundles on Lagrangians. Therefore, \hat{G} acts both on the G -equivariant category and on the orbifolded Fukaya category. The original Fukaya category of M does not contain the data of G -equivariant structure of unitary bundles. Hence, one needs to take the \hat{G} -invariant part of equivariant fukaya category $G\text{-}\mathcal{Fuk}^s(M)$ to obtain information about the Fukaya category of M itself.

13. Fukaya-Seidel category of G -Lefschetz fibrations

There is a well-known Fukaya category associated to a Lefschetz fibration $\pi : E \rightarrow S$, called the Fukaya-Seidel category of π [39], [40]. If the Lefschetz fibration π is G -invariant, i.e. if there is a G -action on E such that the fibration map π is G -invariant, then we can define the G -equivariant Fukaya-Seidel category of π and the orbifolded Fukaya-Seidel category of $\bar{\pi} : [E/G] \rightarrow S$. These will depend on the choice of a group cohomology class s in $H^2(G, \mathbb{Z}/2)$. The construction is more or less an easy modification of Seidel’s construction.

13.1. Equivariant Fukaya-Seidel categories

First, we review basic ingredients of Fukaya-Seidel categories. (See [37] for details.) Let $\pi : E \rightarrow S$ be an exact Morse fibration where E admits an exact symplectic form ω and S is isomorphic to D^2 . We assume that $c_1(E) = 0$ in order to discuss \mathbb{Z} -grading, and assume $\dim_{\mathbb{R}}(E) \geq 4$ to simplify the exposition. Suppose there exists a ω -preserving G -action on E and π is invariant under G . Then, the symplectic connection defined by ω is G -invariant, and hence a parallel transport $\rho_c : E_z \rightarrow E_w$ along a curve $c : [a, b] \rightarrow S$ is a G -equivariant diffeomorphism.

Let z_0 be a regular value of π and M the fiber of π over z_0 . If $\{z_1, \dots, z_n\} \in S$ is the set of critical values of π , we choose disjoint paths c_i (except at z_0) from z_0 to z_i for each $1 \leq i \leq n$. (c_1, \dots, c_n) are arranged by their cyclic order at z_0 . See Figure 10 where we set $z_0 = -i$. There may be several dif-

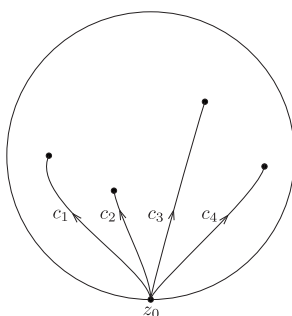

Figure 10: Configuration of vanishing paths.

ferent critical points over single critical value z_i . Denote by $a(i)$ the number

of critical points over z_i . Then, the parallel transport along c_i defines a set of vanishing cycles $\sqcup_{j=1}^{a(i)} V_{ij}$. Since G acts on these $a(i)$ critical points, G also acts on the set of vanishing cycles $\sqcup_{j=1}^{a(i)} V_{ij}$. We do not need to give an ordering to the family of vanishing cycles for c_i , because they are disjoint from each other, and hence Floer cohomology groups and Dehn twists between them are all trivial.

As usual, we also pay attention to the Lefschetz thimbles which will be denoted by Δ_{ij} 's. More precisely, Δ_{ij} is the union of images of the vanishing cycle V_{ij} under the parallel transport over c_i so that $\partial\Delta_{ij} = V_{ij}$. Since the symplectic connection as well as π are G -invariant, the group G acts on the union of Lefschetz thimbles over each c_i , and we immediately obtain the following lemma.

Lemma 13.1. *For each i and $g \in G$, we have $g(\Delta_{ij}) = \Delta_{ik}$ for some $k \in \{1, \dots, a(i)\}$. Namely, an action of each $g \in G$ permutes thimbles over the given path c_i (while some of thimbles can be preserved by g).*

Gradings and spin structures on vanishing cycles are defined as follows. As explained right after Definition 6.1, we can equip V_{ij} 's with G -invariant gradings. If $\dim_{\mathbb{R}}(M) \geq 4$, then the vanishing cycles are spheres of $\dim \geq 2$, which have canonical spin structures. In case $\dim_{\mathbb{R}}(M) = 2$, vanishing cycles are circles, and we choose a spin structures of each vanishing cycle to be the one obtained from the restriction of the trivialization of the tangent bundle of the corresponding Lefschetz thimble.

We remark that an object consists of a single connected component if G -action preserves V_{ij} , and has several disjoint components otherwise. For example, if there is only one critical point over the critical value z_i , then the vanishing cycle V_{i1} is preserved by the G -action and is an object of the category as this critical point should be fixed by the whole group G .

Now, we define an equivariant (or an orbifold) version of a directed A_{∞} -category \mathcal{FS} , so called the Fukaya-Seidel category. For each s in $H^2(G; \mathbb{Z}/2)$, we will have a category consisting of s -equivariant branes, which are G -invariant (union of) vanishing cycles with the spin profile s .

Definition 13.2. Consider a G -invariant Lefschetz fibration $\pi : M \rightarrow \mathbb{C}$, and choice of paths $\{c_i\}$ and vanishing cycles $\{V_{ij}\}$ as before. An object of both the s -equivariant Fukaya-Seidel category $G\text{-}\mathcal{FS}^s(M, \pi)$ and orbifold Fukaya-Seidel category $\mathcal{FS}_G^s(M, \pi)$ is given by a G -orbit $\cup_{gg \cdot V_{ij}}$ for each vanishing cycle V_{ij} for some $1 \leq i \leq n, 1 \leq j \leq a(i)$ whose spin profile is s , together with a G -invariant grading and G -equivariant flat complex vector

bundle on $\cup_g g \cdot V_{ij}$. We require that this bundle extends to a G -equivariant flat complex vector bundle on the corresponding thimble. We denote by \mathcal{V}_{ij} the G -orbit of vanishing cycle $\cup_g g \cdot V_{ij}$ together with these additional data. Also, if V_{ij} and $V_{ij'}$ lie in the same G -orbit, then we identify $\cup_g g \cdot V_{ij}$ and $\cup_g g \cdot V_{ij'}$.

The objects of equivariant and orbifold categories are the same as above, but their morphisms will be defined differently. We postpone the discussion of adding G -equivariant flat complex vector bundle to the construction in Subsection 13.2, and we first explain the construction without them.

We may suppose that all vanishing cycles (and hence, all objects in \mathcal{C}) are transversal to each other by choosing vanishing paths in general positions (Figure 10). The cyclic order at z_0 gives a partial order, on the index i of V_{ij} .

Definition 13.3. We define morphisms between two objects $\mathcal{V}_{i_1 j_1}$ and $\mathcal{V}_{i_2 j_2}$ of the s -equivariant category $G\text{-}\mathcal{F}\mathcal{S}^s(M, \pi)$ as follows.

For $i_1 \neq i_2$,

$$\begin{aligned} & \text{hom}_{G\text{-}\mathcal{F}\mathcal{S}^s}(\mathcal{V}_{i_1 j_1}, \mathcal{V}_{i_2 j_2}) \\ &= \begin{cases} CF^*(\mathcal{V}_{i_1 j_1}, \mathcal{V}_{i_2 j_2}) = \bigoplus_{y \in \mathcal{V}_{i_1 j_1} \cap \mathcal{V}_{i_2 j_2}} |o(y)|_R & k < l \\ 0 & k > l \end{cases} \end{aligned}$$

For $i_1 = i_2$, and two objects $\mathcal{V}_{i_1 j_1}$ and $\mathcal{V}_{i_2 j_2}$ are in fact the same, then we define

$$\text{hom}_{G\text{-}\mathcal{F}\mathcal{S}^s}(\mathcal{V}_{i_1 j_1}, \mathcal{V}_{i_1 j_1}) = R \cdot (id_{V_1} \oplus \cdots id_{V_k}).$$

For the remaining case, their morphisms are defined to be zero (since they do not intersect).

Remark 13.4. This A_∞ -category is not strictly but partially directed in a sense.

Note that the morphism space admits a G -action. For $\mathcal{V}_{i_1 j_1} \neq \mathcal{V}_{i_2 j_2}$, the G -action on their morphism is exactly the same as in Section 6. If $i_1 = i_2$ and two objects $\mathcal{V}_{i_1 j_1}$ and $\mathcal{V}_{i_2 j_2}$ are the same, then the G -action on $R \cdot (id_{V_1} \oplus \cdots id_{V_k})$ is defined as follows. We first fix orientations of V_1, \dots, V_k , and the construction below depends on this choice. Since \mathcal{V} is a G -orbit, each connected component V_i is mapped to V_j for some j . In such a case, we define g -action $R \cdot id_{V_i} \rightarrow R \cdot id_{V_j}$ to be (± 1) , where the sign is positive if the g -action preserves the pre-fixed orientations, and negative otherwise. This defines G -action on morphism spaces.

In order to construct G -equivariant A_∞ -operations on morphisms of $G\text{-}\mathcal{F}\mathcal{S}^s(M, \pi)$, we may adapt the construction in the previous section. Namely, we consider a A_∞ -category \mathcal{D} , whose object is (\mathcal{V}_{ij}, g) for each i, j and $g \in G$. Then the set of object of \mathcal{D} admits a free G -action, and we can make the perturbation data G -equivariant. As Seidel mentioned in [39, Remark 6.1], we do not have to care about the chain complexes underlying $HF(\mathcal{V}_{ij}, \mathcal{V}_{ij})$ by the (partial) directedness, but only the above case $(k_0 < \dots < k_d)$ is needed to be considered. Therefore, the homological perturbation lemma of Seidel (Lemma 6.7) provides G -equivariant A_∞ -operations on morphisms of $G\text{-}\mathcal{F}\mathcal{S}^s(M, \pi)$.

Definition 13.5. For the orbifold Fukaya-Seidel category, morphisms of $\mathcal{F}\mathcal{S}_G^s(M, \pi)$ are defined to be the G -invariant part of the corresponding morphisms of $G\text{-}\mathcal{F}\mathcal{S}^s(M, \pi)$, which has an induced A_∞ -operations.

13.2. Equivariant flat unitary bundles for $G\text{-}\mathcal{F}\mathcal{S}^s(M, \pi)$

Even though vanishing cycles \mathcal{V} give rise to objects of directed A_∞ -category, one has to think in terms of respective vanishing thimbles denoted as \mathcal{T} , which are indeed Lagrangian submanifolds in M . We assume here that G is abelian in order to simplify the exposition. General cases can be handled as in Section 12. Note that any irreducible representation of G is 1-dimensional and hence, it suffices to consider line bundles only.

Consider $\mathcal{V} := \cup_g g \cdot V_{ij}$ for each i, j and the G -equivariant line bundle U on \mathcal{V} which extends to the one on the corresponding thimble \mathcal{T} . Let us denote it by $U^{\mathcal{T}} \rightarrow \mathcal{T}$, which is necessarily trivial. Thus, $U^{\mathcal{T}} \cong \mathcal{T} \times \mathbb{C}$ and the G -equivariant structure on $U^{\mathcal{T}}$ comes up with $\chi \in \text{Hom}(G, \mathbb{C}^*)$.

Suppose that \mathcal{V}_i is a vanishing cycles with a G -equivariant line bundle $U_i^{\mathcal{T}}$ as above for $i = 1, 2$. Then, pairs $(\mathcal{V}_i, U_i^{\mathcal{T}})$ for $i = 1, 2$ are objects of $G\text{-}\mathcal{F}\mathcal{S}^s(M, \pi)$ and we want to define their morphism space.

If $\mathcal{V}_1 \neq \mathcal{V}_2$ We define their morphism space to be as in section 13 using $o(y)$ for each intersection points y but with \mathbb{C} coefficients. The group action on the morphism space is twisted by χ_1 and χ_2 . i.e. $g : o(y) \rightarrow o(g \cdot y)$ is defined as the original action multiplied by $\chi_1(g)^{-1}\chi_2(g)$. This is a canonical action on $o(y) \otimes \text{Hom}(U_0^{\mathcal{T}}|_y, U_1^{\mathcal{T}}|_y)$ consistent with (12.3). However, since $U_i^{\mathcal{T}}|_y$ is canonically isomorphic to \mathbb{C} , we may just use $o(y)$ as above.

Let us consider the case $\mathcal{V}_1 = \mathcal{V}_2 =: \mathcal{V}$. Denote the connected components of \mathcal{V} as V_1, \dots, V_k associated to critical points x_1, \dots, x_k . Recall that

$\text{Hom}(\mathcal{V}, \mathcal{V})$ (with $R = \mathbb{C}$) is given by

$$(13.1) \quad \mathbb{C} \cdot (id_{V_1} \oplus \cdots \oplus id_{V_k}).$$

The G -action on the above morphism space has been already described in Section 7. When they are equipped with G -equivariant line bundles, $\text{Hom}((\mathcal{V}, U_1^T), (\mathcal{V}, U_2^T))$ is defined to be the same as (13.1), whose g -action is given by the previous g -action defined in section 13 with additional multiplication of $\chi_1(g)^{-1}\chi_2(g)$.

Note that the G -invariant part $\text{Hom}((\mathcal{V}, U_1^T), (\mathcal{V}, U_2^T))^G$ is non-trivial if G -action on the set of connected components of \mathcal{V} is free.

14. Some examples of group actions and mirror symmetry

We discuss a few examples of well-known homological mirror symmetry, but with an additional finite group action. The homological mirror symmetry (conjectured by Kontsevich) asserts that the derived Fukaya category of a symplectic manifold (or the derived Fukaya-Seidel category of a LG model) is equivalent to the derived category of coherent sheaves of the mirror complex manifold (or the matrix factorization category of the mirror LG model). Strominger-Yau-Zaslow approach explains such a phenomenon as a correspondence between dual torus fibrations. We will be rather sketchy, as our motivation is to consider its relationship with group actions.

Consider a Lagrangian torus fibration $\pi : X \rightarrow B$ where $\pi^{-1}(b)$ is regular torus fiber for $b \in \mathring{B}$, and assume that \mathring{B} is simply connected. Suppose that the mirror is given as a Landau-Ginzburg (LG) model $W : Y \rightarrow \mathbb{C}$. Here, $Y \rightarrow \mathring{B}$ is the dual torus fibration

$$Y = \{(X_b, \nabla_b) : \nabla_b \in \text{Hom}(X_b, U(1)), b \in \mathring{B}\}$$

where $\text{Hom}(H_1(X_b), U(1))$ is considered to be the space of flat connections on the trivial line bundle on X_b . Suppose that the mirror potential $W : Y \rightarrow \mathbb{C}$ is defined as a Lagrangian Floer potential (see for example [17], [26], [5])

$$W(L_u, \nabla_u) = \sum_{\beta, \mu(\beta)=2} n_\beta(L_u) \exp\left(-\int_\beta \omega\right) \text{hol}_{\nabla_u}(\partial\beta).$$

Definition 14.1. We say that an action of a finite group G on X is compatible with the fibration π if the group action sends torus fibers to torus fibers.

We will assume that G acts on $X \rightarrow B$ in a compatible way from now on. Thus each $g \in G$ sends a fiber X_b into $X_{b'}$ for some b' for each $b \in B$.

Definition 14.2. We define the G -action on Y as

$$g \cdot (X_b, \nabla_b) = (X_{g \cdot b}, g_* \nabla_b).$$

(Here, $g_* \nabla_b := (g^{-1})^* \nabla_b$.)

Note that this G -action could be trivial even if the G -action on X is effective as we will see in the example of $\mathbb{C}P^1$. For a G -action on X compatible with π , we have an induced homomorphism $\rho : G \rightarrow \text{Aut}(B)$. This gives rise to the following exact sequence

$$1 \rightarrow \text{Ker}(\rho) \rightarrow G \rightarrow G/\text{Ker}(\rho) \rightarrow 1.$$

We may denote $G_F = \text{Ker}(\rho)$ and $G_B = G/\text{Ker}(\rho)$. The example of $\mathbb{C}P^1$ below is the case when $G = G_F$. But if $G = G_B$, it is clear that G -action on Y is also effective if that on X is. We will see such an example in the Section 15, where the G -action on $\mathbb{C}P^2$ rotates the moment triangle B .

It is not hard to show that W becomes G -invariant for the induced G -action on Y .

Lemma 14.3. $W : Y \rightarrow \mathbb{C}$ is G -invariant.

Proof. It follows from the invariance of the symplectic form ω under the G -action:

$$\begin{aligned} W(X_{g \cdot b}, g_* \nabla_b) &= \sum_{\substack{\beta' \in \pi_2(X, X_{g \cdot b}) \\ \mu(\beta')=2}} n_{\beta'}(X_{g \cdot b}) \exp\left(-\int_{\beta'} \omega\right) \text{hol}_{g_* \nabla_b}(\partial\beta') \\ &= \sum_{\substack{\beta \in \pi_2(X, X_b) \\ \mu(\beta)=2}} n_{g \cdot \beta}(X_{g \cdot b}) \exp\left(-\int_{g \cdot \beta} \omega\right) \text{hol}_{g_* \nabla_b}(\partial(g \cdot \beta)) \\ &= \sum_{\substack{\beta \in \pi_2(X, X_b) \\ \mu(\beta)=2}} n_{\beta}(X_b) \exp\left(-\int_{\beta} \omega\right) \text{hol}_{\nabla_b}(\partial\beta) = W(X_b, \nabla_b) \end{aligned}$$

□

We denote by s the spin profile of torus fibers X_b for $b \in \mathring{B}$. We can formulate the homological mirror symmetry conjecture in this setting as follows:

Conjecture 14.4. *There are equivalences of derived categories,*

$$(14.1) \quad D^b \mathcal{Fuk}_G^s(X) \cong D^b MF_G(W)$$

$$(14.2) \quad D^b \mathcal{FS}_G^s(Y, W) \cong D^b Coh_G X$$

where $D^b \mathcal{Fuk}_G^s(X)$ is the derived s -orbifolded Fukaya category of X defined in this paper, $D^b Coh_G(X)$ is the derived category of G -equivariant coherent sheaves on X and $MF_G(W)$ is the G -equivariant matrix factorization category of W . The character group \hat{G} acts on both sides of (14.1) by twisting equivariant structures in a compatible way.

In general, for a mirror pair X, Y , one may conjecture the equivalence of two categories $D^b \mathcal{Fuk}_G^s(X)$ and $D^b Coh_G(Y)$. Here, note that the right hand sides do not involve spin profiles. This is because sheaves on the right hand side are expected to be obtained as certain family version of Floer homologies, and hence G -action is well-define for them (without spin profiles). Note also that the right hand side is well-defined even when G acts trivially.

14.1. Fiberwise G_F -actions and toric examples

Suppose that an abelian group $G = G_F$ acts freely on regular torus fibers. In particular, the character group G^* is the dual group of G . Its dual torus fibration can be understood as follows. Consider

$$(14.3) \quad 1 \rightarrow \pi_1(X_b) \rightarrow \pi_1^{orb}([X_b/G]) \rightarrow G \rightarrow 1$$

and take $\text{Hom}(-, U(1))$ to obtain the following exact sequence:

$$(14.4) \quad 0 \rightarrow G^* = \text{Hom}(G, U(1)) \rightarrow \tilde{Y}_b := \text{Hom}(\pi_1^{orb}([X_b/G]), U(1)) \rightarrow Y_b = \text{Hom}(\pi_1(X_b), U(1)).$$

If X_b/G_F is still a (Lagrangian) torus, then the last map $\tilde{Y}_b \rightarrow Y_b$ is surjective. This follows from the fact that the first and the second term in the exact sequence (14.3) are isomorphic to \mathbb{Z}^n and $U(1)$ is divisible.

Let us assume that $X/G_F \rightarrow B$ is again a Lagrangian torus fibration from now on. This happens for example when X is a toric manifold with the action of a finite subgroup $G = G_F$ of the torus $U(1)^n \subset (\mathbb{C}^*)^n$.

Since $\pi_1^{orb}([X_b/G]) = \pi_1(X_b/G)$, the middle term \tilde{Y}_b gives the dual torus fiber of X_b/G , giving rise to the dual torus fibration $\tilde{Y} \rightarrow \tilde{B}$. From (14.4), it is easy to see that the dual group G^* acts on \tilde{Y} and the quotient is

isomorphic to the mirror manifold Y of X . Let $p: \tilde{Y} \rightarrow Y$ be the quotient map via G^* . Indeed G^* acts on \tilde{Y} freely and $p: \tilde{Y} \rightarrow Y$ is a covering whose deck transformation group is precisely G^* since the first map in (14.4) is injective.

Let $\tilde{W}: \tilde{Y} \rightarrow \mathbb{C}$ be given by the composition $W \circ p$. \tilde{W} is G^* -invariant by definition. We define \widetilde{W} by the composition because smooth holomorphic discs in $[X/G]$ are in fact obtained from smooth holomorphic discs in X . (See [18] for more details: we do not consider bulk-deformations by twisted sectors, here.)

The situation is summarized in the diagram below:

$$\begin{array}{ccccc}
 X & \xleftarrow{\text{mirror}} & Y & \xrightarrow{W} & \mathbb{C} \\
 \downarrow G & & \uparrow G^* & \nearrow \tilde{W} & \\
 [X/G] & \xleftarrow{\text{mirror}} & \tilde{Y} & & .
 \end{array}$$

Namely, in this case, taking G -quotient on one side corresponds to taking a G^* -covering on the other side. We remark that such a phenomenon has been already observed for the pair of pants case by Abouzaid, Auroux, Efimov, Katzarkov and Orlov [1].

Now, it is natural to expect that (\tilde{Y}, \tilde{W}) is the LG mirror of $[X/G]$ in the sense of SYZ. Moreover, the A -model category for X and the one for its quotient are expected to have a close relationship.

Conjecture 14.5. *In the above setting, we have equivalences of derived categories*

$$D^b \mathcal{F}uk_G^s(X) \cong D^b MF(\tilde{W})$$

and

$$D^b \mathcal{F}uk(X) \cong (D^b \mathcal{F}uk_G^s(X))^{G^*}.$$

Here, $MF_{G^*}(\tilde{W})$ is the G^* -equivariant matrix factorization category. As the G^* -action on \tilde{Y} is free, $MF_{G^*}(\tilde{W})$ is equivalent to $MF(W)$ where the equivalence from $MF(W)$ to $MF_{G^*}(\tilde{W})$ is the pull-back functor by the projection $\tilde{Y} \rightarrow Y$. (This is a special case of Proposition 2.2 in [35].) Hence the second part of the conjecture follows from the first part of the conjecture.

We can relate the G^* -action on \tilde{Y} with the G^* -action on $\mathcal{F}uk_G^s(X)$ in a geometric way. In view of SYZ, a point in \tilde{Y}_b corresponds to a torus fiber $[X_b/G]$ together with a flat line bundle over it, or equivalently a G -equivariant flat line bundle (U, θ, ∇) over X_b . Since G acts freely on X_b , a

G -equivariant structure on the line bundle U is unique up to isomorphism. However, if we apply the character group action of $\chi \in G^*$ to (U, θ, ∇) , the flat structure, or holonomy in an orbifold sense, of $[U/G]$ changes as follows.

Consider a generalized curve $\gamma \in \pi_1^{orb}([X_b/G])$ with $\gamma(0) = x_0$ to $\gamma(1) = g \cdot x_0$ where x_0 is the base point for $\pi_1(X_b)$. After projecting down to $[X_b/G]$, γ becomes a genuine loop $\bar{\gamma}$. Then, the holonomy along the loop $\bar{\gamma}$ in $[X_b/G]$ can be measured by the difference between the parallel transport along γ and θ_g , both of which are linear maps from U_{x_0} and $U_{g \cdot x_0}$. If (U, θ, ∇) is twisted by an element $\chi \in G^*$, then the identification θ_g of U_{x_0} and $U_{g \cdot x_0}$ is also twisted by $\chi(g)$. i.e. U_{x_0} and $U_{g \cdot x_0}$ are now identified by $\chi(g)\theta_g$. As a result, the holonomy around $\bar{\gamma}$ in $[X_b/G]$ is changed by $\chi(g)$. This explains the action of G^* on \tilde{Y}_b shown in (14.4).

14.2. Example of $\mathbb{C}P^1$

We provide an example which illustrate the phenomenon discussed in the previous subsection. Equip $X := \mathbb{C}P^1$ with the $\mathbb{Z}/3$ -action given by $[z_0 : z_1] \rightarrow [\rho z_0 : z_1]$ where $\rho = e^{2\pi i/3}$. It preserves all torus fibers, and hence $G = G_F$ in this example. Associated to this action, we can construct a three-fold cover \tilde{Y} of the mirror $Y := \mathbb{C}^*$ of X . Identifying \tilde{Y} with \mathbb{C}^* , the covering map is explicitly given by

$$w \in \tilde{Y} \mapsto z = w^3 \in Y.$$

The $G^*(\cong \mathbb{Z}/3)$ -action on \tilde{Y} (14.4) sends w to ρw .

Remark 14.6. The variable w indeed comes from orbidisks bounding torus fibers in $[X/G]$. In Figure 11, $w = T^{\omega(\beta)} hol_{\nabla} \partial \beta$. See [18] or [15] for more details.

Then, in terms of a coordinate w on \tilde{Y} , the pulled-back potential \tilde{W} can be written as

$$\tilde{W} = w^3 + \frac{1}{w^3}.$$

(For simplicity, we set the Kähler parameter q to be 1.) Note that \tilde{W} is invariant under the G^* -action. Consider the Lagrangian brane \mathcal{L} supported on the balanced torus fiber with the trivial holonomy in $[X/G]$. In [15], it is shown that the SYZ transformation of \mathcal{L} is the following matrix factorization

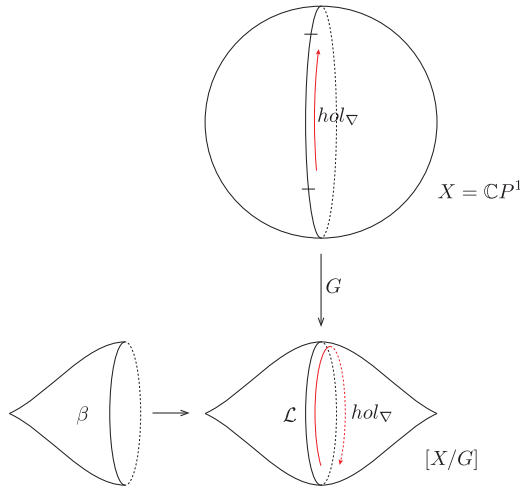

Figure 11.

of \widetilde{W} .

$$(14.5) \quad (1 - w) \left(\frac{1}{w^3} + \frac{1}{w^2} + \frac{1}{w} - 1 - w - w^2 \right) = w^3 + \frac{1}{w^3} - 2$$

Notice that 2 is a critical value of \widetilde{W} . Now, $\rho \in G^*$ sends \mathcal{L} to the Lagrangian brane supported on the same torus fiber but with the holonomy ρ . In the mirror, it sends (14.5) to

$$(1 - \rho w) \left(\frac{1}{w^3} + \frac{1}{\rho^2 w^2} + \frac{1}{\rho w} - 1 - \rho w - \rho^2 w^2 \right) = w^3 + \frac{1}{w^3} - 2,$$

where we used $\rho^3 = 1$.

There is an easy example of a G^* -invariant object in $MF(\widetilde{W})$, which can be written down only in terms of w^3 :

$$(14.6) \quad (1 - w^3) \left(\frac{1}{w^3} - 1 \right) = w^3 + \frac{1}{w^3} - 2.$$

Using $z = w^3$, (14.6) is expressed as

$$(1 - z) \left(\frac{1}{z} - 1 \right) = z + \frac{1}{z} - 2 (= W - 2),$$

which was shown to be the mirror matrix factorization of the equator in $\mathbb{C}P^1$ in [8].

15. $\mathbb{C}P^2$ with a $\mathbb{Z}/3$ -action

In this section, we consider the projective plane $\mathbb{C}P^2$ equipped with the $G = \mathbb{Z}/3$ -action which cyclically permutes three homogeneous coordinate of $[z_0 : z_1 : z_2]$ in $\mathbb{C}P^2$. Note that the torus fibration $\mathbb{C}P^2 \rightarrow \Delta$ is compatible with this $\mathbb{Z}/3$ -action. The Landau-Ginzburg mirror of $\mathbb{C}P^2$ is given by $\{xyz = 1\} \subset \mathbb{C}^3$ with the superpotential $W(x, y, z) = x + y + z$. It is easily check that the mirror $\mathbb{Z}/3$ -action also permutes three variable x, y , and z , and hence W is invariant under this action. In what follows, we identify the mirror of $\mathbb{C}P^2$ with $(\mathbb{C}^*)^2$ and use $W(x, y) = x + y + \frac{1}{xy}$ as the superpotential.

We will compare $D_{\mathbb{Z}/3}^b Coh(\mathbb{C}P^2)$ and $\mathcal{F}S_{\mathbb{Z}/3}(W)$ in Subsection 15.1, and compare $\mathbb{Z}/3$ -invariant objects in $\mathcal{F}uk(\mathbb{C}P^2)$ and $D_{sing}^b(W)$ in Subsection 15.2.

Let us first remark on spin profiles and energy zero subgroups. For $\mathcal{F}uk(\mathbb{C}P^2)$, we will consider the Floer homology of a torus fiber with itself, and in such a case a choice of spin profile does not affect the group action. Indeed, spin profiles for invariant Lagrangians involved in this example are all zero since $H^2(\mathbb{Z}/3, \mathbb{Z}/2) = 0$. Also the central fiber has a fixed point of group action. Thus from Lemma 8.5, we have $G_\alpha = G$, and we can define G -actions on Lagrangian Floer homology groups.

15.1. Comparison of $D_{\mathbb{Z}/3}^b Coh(\mathbb{C}P^2)$ and $\mathcal{F}S_{\mathbb{Z}/3}(W)$

The following discussion is based on the computations in [4] except that we additionally consider the group action.

Before going into details, we briefly recall what equivariant sheaves are. Let X be a topological space with an action of a finite group G .

Definition 15.1. A G -equivariant structure on a sheaf \mathcal{F} on X is a choice of an isomorphism $\theta_g : \mathcal{F} \cong g^*\mathcal{F}$ for each g such that these isomorphisms satisfy the cocycle condition

$$(15.1) \quad \theta_{gh} = h^*\theta_g \circ \theta_h.$$

Since $(g^*\mathcal{F})_x = \mathcal{F}_{g \cdot x}$ for $x \in X$, the G -equivariant structure on \mathcal{F} gives an isomorphism $\theta_g(x) : \mathcal{F}_x \xrightarrow{\cong} \mathcal{F}_{g \cdot x}$ for each $g \in G$ which covers the base

action.

$$(15.2) \quad \begin{array}{ccc} \mathcal{F}_x & \xrightarrow{\theta_g(x)} & \mathcal{F}_{g \cdot x} \\ \downarrow & & \downarrow \\ x & \xrightarrow{g} & g \cdot x \end{array} \quad \begin{array}{ccc} \mathcal{F}_x & \xrightarrow{\theta_{gh}(x)} & \mathcal{F}_{(gh) \cdot x} \\ \searrow \theta_h(x) & & \nearrow \theta_g(h \cdot x) \\ & \mathcal{F}_{h \cdot x} & \end{array}$$

On the level of stalks, the cocycle condition (15.1) can be understood more clearly shown in the right side diagram in (15.2).

Denote the category of G -equivariant sheaves by $Sh_G(X)$ and define

$$(15.3) \quad Coh^G(X) := \{(\mathcal{F}, \theta) \in Sh_G(X) : \mathcal{F} \in Coh(X)\}.$$

We write $D_G^b Coh(X)$ for the derived category of (15.3). The original definition of $D_G^b Coh(X)$ is slightly different from the one given here, but it is known that they are equivalent if G is finite. (See [7].)

(i) We first find generators $D_{\mathbb{Z}/3}^b Coh(\mathbb{C}P^2)$. Before describing the equivariant version, we recall the following well-known fact.

Proposition 15.2. [6] *Let $\Omega = \Omega^1$ be the cotangent sheaf on $\mathbb{C}P^2$. Then,*

$$(15.4) \quad \Omega^2(2), \quad \Omega^1(1), \quad \Omega^0 = \mathcal{O}$$

forms a full strong exceptional collection in $D^b(Coh(\mathbb{C}P^2))$.

Remark 15.3. There is another well-known generators of $D^b Coh(\mathbb{C}P^2)$, $\{\mathcal{O}, \mathcal{O}(1), \mathcal{O}(2)\}$. See [6] or [4, Theorem 2.12].

It is also known from [6] that

$$(15.5) \quad RHom(\Omega^1(1), \mathcal{O}) \cong RHom(\Omega^2(2), \Omega(1)) \cong \mathbb{C} \langle x \rangle \oplus \mathbb{C} \langle y \rangle \oplus \mathbb{C} \langle z \rangle,$$

and

$$(15.6) \quad RHom(\Omega^2(2), \mathcal{O}) \cong \mathbb{C} \langle x \wedge y \rangle \oplus \mathbb{C} \langle y \wedge z \rangle \oplus \mathbb{C} \langle z \wedge x \rangle.$$

Note that three sheaves in Proposition 15.2 are all $\mathbb{Z}/3$ -invariant. We fix an equivariant structure on each of these sheaves so that the induced action on morphism spaces (15.5) and (15.6) are given by cyclic permutation on dx, dy, dz . Let V_i ($i = 0, 1, 2$) be the irreducible representation of

$\mathbb{Z}/3$ on which the primitive generator of $\mathbb{Z}/3$ acts by ρ^i . Then, any $\mathbb{Z}/3$ -equivariant structure on $\Omega(i)$ is isomorphic to $\Omega(i) \otimes V_j$ for some j . Moreover, for $i_1, i_2, j_1, j_2 \in \{0, 1, 2\}$ with $i_1 \geq i_2$,

$$\text{Hom}_G(\Omega^{i_1}(i_1) \otimes V_{j_1}, \Omega^{i_2}(i_2) \otimes V_{j_2}) \cong (\text{Hom}(\Omega^{i_1}(i_1), \Omega^{i_2}(i_2)) \otimes V_{j_2-j_1})^G.$$

(See the proof of [19, Theorem 2.1].) If i_1 is strictly greater than i_2 , then $\dim \text{Hom}(\Omega^{i_1}(i_1), \Omega^{i_2}(i_2)) = 3$ and G permutes its basis (which are chosen in (15.5) and (15.6)). Therefore, the rank of the right hand side is 1 regardless of j_1 and j_2 . However, if $i_1 = i_2 = i$, then

$$(15.7) \quad \text{Hom}_G(\Omega^i(i) \otimes V_{j_1}, \Omega^i(i) \otimes V_{j_2}) \cong V_{j_2-j_1}^G \cong \mathbb{C}^{\delta_{j_1 j_2}}.$$

(ii) The mirror $\mathbb{Z}/3$ -action fixes three critical points of W ,

$$p_0 = (1, 1), \quad p_1 = (\rho, \rho), \quad p_2 = (\rho^2, \rho^2),$$

where $\rho = e^{2\pi i/3}$. They are indeed the only fixed points of this $\mathbb{Z}/3$ -action. We have vanishing cycles V_0, V_1 and V_2 in $W^{-1}(0)$ associated to p_0, p_1 , and p_2 respectively. Each V_i is a $\mathbb{Z}/3$ -invariant Lagrangian submanifold of $W^{-1}(0)$. Since the $\mathbb{Z}/3$ -action on $W^{-1}(0)$ is free, the action on V_i is topologically equivalent to the one generated by the $2\pi i/3$ -rotation on the circle ($\cong V_i$) and in particular, it is orientation preserving. We equip V_i 's with nontrivial spin structures (which extend to the vanishing thimbles). As mentioned, we do not need to care about spin profiles as $H^2(\mathbb{Z}/3, \mathbb{Z}/2)$ is zero and therefore, the group action lifts to the spin bundles.

By projecting to the x -coordinate plane (minus the origin), we see that each pair of vanishing cycles intersects at three points. We denote them as

$$\begin{aligned} V_0 \cap V_1 &= \{x_0, y_0, z_0\}, \\ V_1 \cap V_2 &= \{x_1, y_1, z_1\}, \\ V_0 \cap V_2 &= \{\bar{x}_0, \bar{y}_0, \bar{z}_0\}. \end{aligned}$$

Since the group action is free on $W^{-1}(0)$, it also freely permutes three points in $V_i \cap V_j$ for $i \neq j \in \{0, 1, 2\}$. From [4],

Lemma 15.4. *m_1 is identically zero.*

(For the full computation of the A_∞ structure of the Fukaya-Seidel category of W , see [4].)

Now, we consider the equivariant vector bundles on V_i 's. Recall from Section 12 that such bundles extend to the vanishing thimbles (Δ_i 's) so that the equivariant structures are determined by characters in $(\mathbb{Z}/3)^* = \text{Hom}(\mathbb{Z}/3, U(1)) (\cong \mathbb{Z}/3)$. Let χ_i ($i = 0, 1, 2$) be the character that sends the primitive generator of $\mathbb{Z}/3$ to $\rho^i \in U(1)$ ($\rho = e^{2\pi i/3}$). Then, the $\mathbb{Z}/3$ -equivariant Fukaya-Seidel category has 9 objects : (V_i, χ_j) , $i, j \in \{0, 1, 2\}$.

One can easily check that if $i_1 \neq i_2$, the G -invariant part of

$$\text{Hom}((V_{i_1}, \chi_{j_1}), (V_{i_2}, \chi_{j_2}))$$

is of rank 1 (regardless of j_1 and j_2) since the G -action is free. If $i_1 = i_2$ but $\chi_{j_1} \neq \chi_{j_2}$, then the $\mathbb{Z}/3$ -action on $\mathbb{C} (\cong \mathbb{C} \cdot id_{V_i})$ is nontrivial as $\chi_1(g)^{-1}\chi_2(g) \neq 1$ for some $g \in \mathbb{Z}/3$. Therefore, there can not exist any g -invariant element other than zero. Hence we have

$$\text{Hom}((V_i, \chi_{j_1}), (V_i, \chi_{j_2})) \cong \mathbb{C}^{\delta_{j_1, j_2}}$$

15.2. Equivariant A -branes in $\mathbb{C}P^2$ and B -branes in its mirror

(i) In $\mathbb{C}P^2$, there are three nontrivial A -branes, the Clifford torus T , together with three different holonomies, $(T, (1, 1))$, $(T, (\rho, \rho))$ and $(T, (\rho^2, \rho^2))$, which are known to have non-vanishing Floer homologies [12]. In fact they are expected to generate the Fukaya category of $\mathbb{C}P^2$ which has been announced by Abouzaid, Fukaya, Oh, Ohta and Ono [2].

The central fiber T is preserved by the $\mathbb{Z}/3$ -action. As the values of the (Lagrangian Floer) potential function are distinct for these three A -branes, Floer homologies between them are not defined, but only Floer homologies for the same pairs of objects are defined, which turn out to be isomorphic to the singular cohomology of T (as modules). We work with $\mathbb{Z}/2$ -grading, and hence both the even and the odd degree components of their endomorphism spaces have rank 2. Let us consider $(T, (1, 1))$ only, since the other cases are almost the same. We identify $HF(T, T)$ with the space of harmonic forms on T , which is generated by $d\theta_0, d\theta_1, d\theta_2$ (and their products as well) with the relation $d\theta_0 + d\theta_1 + d\theta_2 = 0$. The induced action on T sends $d\theta_i$ to $d\theta_{i+1}$ (with $i + 3 = i$). One can easily check that 1 and $d\theta_0 \wedge d\theta_1$ is invariant under this action. However, the G -invariant part of $HF(T, T)$ does not have any 1-forms since the only 1-form possibly G -invariant is $d\theta_0 + d\theta_1 + d\theta_2 (= 0)$.

(ii) Likewise, among three critical value $3, 3\rho$, and $3\rho^2$ of the potential $W = x + y + \frac{1}{xy}$, we only consider the category $D_{sing}^b(W^{-1}(3))$. $W^{-1}(3)$ has a unique singular point $(x, y) = (1, 1)$, which is nodal. Let \mathcal{F} be the skyscraper

sheaf supported at this point. Note that \mathcal{F} is $\mathbb{Z}/3$ -invariant. We compute $R\mathrm{Hom}(\mathcal{F}, \mathcal{F})$ in the split-closure of $D_{\mathrm{sing}}^b(W^{-1}(3))$.

After the idempotent completion (taking the split-closure), it is enough to consider the skyscraper sheaf $\mathcal{F} = \mathbb{C}_0$ at the origin in $\mathrm{Spec} A$ where $A := \mathbb{C}[x, y]/xy$. Recall from the previous subsection that the action on nearby regular fibers (locally identified with T^*S^1) are induced by $2\pi/3$ -rotations on zero sections. Thus, the continuity of the action shows that the corresponding group action on $\mathrm{Spec} A$ (near the origin) is analytically equivalent to the one given by $(x, y) \mapsto (\rho x, \rho^{-1}y)$. (See Figure 12.)

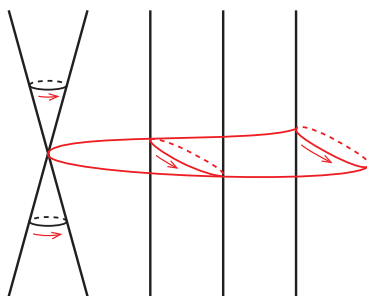

Figure 12: $\mathbb{Z}/3$ -action on $\mathrm{Spec} A$.

Note that we have an exact triangle

$$Ax \oplus Ay \rightarrow A \rightarrow \mathbb{C}_0 \rightarrow [1]$$

consisting of $\mathbb{Z}/3$ -invariant sheaves and that A is a free module. Therefore, \mathbb{C}_0 is isomorphic to $Ax \oplus Ay$ in the derived category of singularities. The even degree part of $R\mathrm{Hom}(Ax \oplus Ay, Ax \oplus Ay)$ is, then, given by

$$(15.8) \quad R\mathrm{Hom}^0(Ax \oplus Ay, Ax \oplus Ay) = \mathrm{Hom}(Ax \oplus Ay, Ax \oplus Ay) \cong \mathbb{C}^2.$$

(Here, $\mathrm{Hom}(Ax \oplus Ay, Ax \oplus Ay)$ means the space of A -module homomorphisms from $Ax \oplus Ay$ to itself which do not factor through a free A -module.)

For $R\mathrm{Hom}^1(Ax \oplus Ay, Ax \oplus Ay) = \mathrm{Hom}(Ax \oplus Ay, Ax \oplus Ay[1])$, we first compute $Ax[1]$ and $Ay[1]$. From the following exact triangle

$$Ax \rightarrow A \rightarrow A/Ax \rightarrow [1]$$

we see that $Ax[1] \cong A/Ax = \mathbb{C}[y](= \mathcal{O}(y - \text{axis}))$. Similarly, $Ay[1] \cong \mathbb{C}[x]$. Therefore,

$$(15.9) \quad R\text{Hom}^1(Ax \oplus Ay, Ax \oplus Ay) = \text{Hom}(Ax \oplus Ay, \mathbb{C}[x] \oplus \mathbb{C}[y]).$$

Any morphism in the right hand side should send x to a constant multiple of $1 \in \mathbb{C}[x]$, or it would factor through A . Likewise, the image of y has to be a multiple of $1 \in \mathbb{C}[y]$. Therefore, $R\text{Hom}^1(Ax \oplus Ay, Ax \oplus Ay) \cong \mathbb{C}^2$.

Note that all sheaves involved here admit natural $\mathbb{Z}/3$ -actions since they are defined by geometric terms preserved by $\mathbb{Z}/3$ (e.g. Ax is the ideal sheaf consisting of regular functions on $\text{Spec } A$ which vanish on y -axis). These actions, of course, can be twisted further by tensoring irreducible representations of $\mathbb{Z}/3$, but we do not consider them here for simplicity.

All elements in (15.8) are clearly invariant under the induced action on (15.8) so that $R\text{Hom}_{\mathbb{Z}/3}^0(Ax \oplus Ay, Ax \oplus Ay) \cong \mathbb{C}^2$. However, $R\text{Hom}_{\mathbb{Z}/3}^1(Ax \oplus Ay, Ax \oplus Ay) = 0$ since the primitive generator of $\mathbb{Z}/3$ acts on $x \in Ax$ and $y \in Ay$ by multiplying ρ , while it keeps both $1 \in \mathbb{C}[x]$ and $1 \in \mathbb{C}[y]$ invariant.

Acknowledgements

We have benefited very much from Paul Seidel's work [37], [38]. We also thank him for helpful comments to our work. We are indebted to Kenji Fukaya for Lemma 9.8 and valuable advices. We are grateful to Kaoru Ono for the kind explanations of orientations in [25], and to Siu-Cheong Lau for several helpful discussions especially on character group actions. We would like to express our gratitude to Yong-Geun Oh, Kwokwai Chan, Hsian-hua Tseng, Mainak Poddar, Nick Sheridan, Hiroshige Kajiuura, Gyoung-Seog Lee, Hyung-Seok Shin, Sangwook Lee for their help. We thank an anonymous referee pointing out an error in the original version of this manuscript. This work was supported by the National Research Foundation of Korea (NRF) grant funded by the Korea Government (MEST) (No. 2012R1A1A2003117)

References

- [1] M. Abouzaid, D. Auroux, A. I. Efimov, L. Katzarkov, and D. Orlov, *Homological mirror symmetry for punctured spheres*, J. Amer. Math. Soc. **26** (2013), 1051–1083.
- [2] M. Abouzaid, K. Fukaya, Y.-G. Oh, H. Ohta, and K. Ono, *Quantum cohomology and split generation in Lagrangian Floer theory*, in preparation.

- [3] A. Adem, J. Leida, and Y. Ruan, *Orbifolds and Stringy Topology*, Cambridge Tracts in Mathematics **171**, Cambridge University Press, Cambridge, 2007.
- [4] D. Auroux, L. Katzarkov, and D. Orlov, *Mirror symmetry for weighted projective planes and their noncommutative deformations*, Ann. of Math. **167** (2008), no. 3, 867–943.
- [5] Denis Auroux, *Mirror symmetry and T-duality in the complement of the anticanonical divisor*, J. Gökova Geom. Topol. **1** (2007), 51–91.
- [6] A. A. Beilinson, *Coherent sheaves on \mathbb{P}^n and problems of linear algebra*, Functional Analysis and its Applications **12** (1978), no. 3, 214–216.
- [7] J. Bernstein and V. Lunts, *Equivariant sheaves and functors*, Springer Lecture Notes **1578** (1994).
- [8] K. Chan and N. C. Leung, *Matrix factorizations from SYZ transformations*, Advances in Geometric Analysis, Adv. Lect. Math. (ALM) **21**, Int. Press, Somerville, MA, 2011.
- [9] W. Chen and Y. Ruan, *A new cohomology theory of orbifold*, Comm. Math. Phys. **248** (2004), 1–31.
- [10] W. Chen and Y. Ruan, *Orbifold quantum cohomology*, Cont. Math. **310**, 25–86.
- [11] W. Chen and Y. Ruan, *Orbifold Gromov-Witten theory*, Orbifolds in mathematics and physics. Contemp. Math. **310**, Amer. Math. Soc., Providence, RI(2002), 25–85.
- [12] C.-H. Cho, *Holomorphic discs, spin structures and the Floer cohomology of the Clifford torus*, IMRN (2004), no. 35, 1803–1843.
- [13] C.-H. Cho and H. Hong, *Orbifold Morse-Smale-Witten complex*, Int. J. Math. **25** (2014), no. 5.
- [14] C.-H. Cho and H. Hong, *Floer cohomology for G -equivariant immersions*, in preparation.
- [15] C.-H. Cho, H. Hong, and S. Lee, *Examples of matrix factorizations from SYZ*, SIGMA **8** (2012), 053.
- [16] C.-H. Cho, H. Hong, and H. S. Shin, *On embeddings between orbifolds*, J. Kor. Math. Soc. **50** (2013), no. 6, 1369–1400.

- [17] C.-H. Cho and Y.-G. Oh, *Floer cohomology and disc instantons of Lagrangian torus fibers in Fano toric manifolds*, Asian J. Math. **10** (2006), no. 4, 773–814.
- [18] C.-H. Cho and M. Poddar, *Holomorphic orbi-discs and Lagrangian Floer cohomology of symplectic toric orbifolds*, J. Diff. Geom. **98** (2014), no. 1, 21–116.
- [19] A. D. Elagin, *Semiorthogonal decompositions of derived categories of equivariant coherent sheaves*, Izvestiya: Mathematics **73** (2009), no. 5, 893.
- [20] A. Floer, *Morse theory for Lagrangian intersections*, J. Diff. Geom. **28** (1988), 513–547.
- [21] K. Fukaya, *Morse homotopy, A_∞ -category and Floer homologies*, in: Proceedings of GARC Workshop on Geometry and Topology, ed. by H. J. Kim, Seoul National University, Korea 1993.
- [22] K. Fukaya, *Deformation theory, homological algebra, and mirror symmetry*, Geometry and physics of branes (Como, 2001), 121–209, Ser. High Energy Phys. Cosmol. Gravit., IOP, Bristol, 2003.
- [23] K. Fukaya, *Floer homology and mirror symmetry II*, Adv. Stud. in Pure Math. **34** (2002), 31–127.
- [24] K. Fukaya and K. Ono, *Arnold conjecture and Gromov-Witten invariants*, Topology **38** (1999), no. 5, 933–1048.
- [25] K. Fukaya, Y.-G. Oh, H. Ohta, and K. Ono, *Lagrangian intersection Floer theory — anomaly and obstruction*, AMS/IP Studies in Advanced Math. **46**, International Press/Amer. Math. Soc. (2009).
- [26] K. Fukaya, Y.-G. Oh, H. Ohta, and K. Ono, *Lagrangian Floer theory on compact toric manifolds I*, Duke Math. J. **151** (2010), 23–174.
- [27] K. Fukaya, Y.-G. Oh, H. Ohta, and K. Ono, *Lagrangian Floer theory on compact toric manifolds II: Bulk deformations*, Selecta Math, New Series **17** (2011), no. 3, 609–711.
- [28] K. Fukaya, Y.-G. Oh, H. Ohta, and K. Ono, *Technical details on Kuranishi structure and virtual fundamental chain*, preprint, [arXiv: 1209.4410](https://arxiv.org/abs/1209.4410).
- [29] M. Kontsevich, *Homological algebra of mirror symmetry*, ICM-1994 proceedings, Zürich, Birkhäuser (1995).

- [30] R. C. Kirby and L. R. Taylor, *Pin structures on Low-dimensional manifolds*, LMS Lec. note series **151**, Camb. Univ. Press, (1990), 177–242.
- [31] E. Lerman and S. Tolman, *Hamiltonian torus actions on symplectic orbifolds and toric varieties*, Trans. Amer. Math. Soc. **349** (1997), 4201–4230.
- [32] J. Milnor, *Spin structures on manifolds*, L’Enseignement Mathematique **9** (1963).
- [33] Y.-G. Oh, *Floer cohomology of Lagrangian intersections and pseudo-holomorphic discs I*, Comm. Pure and Appl. Math. **46** (1993), 949–994 addenda, *ibid*, **48** (1995), 1299–1302.
- [34] K. Ono, *Floer-Novikov cohomology and symplectic fixed points*, J. Symplectic Geom. **3** (2005), 545–563.
- [35] A. Polishchuk and A. Vaintrob, *Matrix factorizations and singularity categories for stacks*, Ann. Inst. Fourier (Grenoble) **61** (2011), no. 7, 2609–2642.
- [36] I. Satake, *On a generalization of the notion of manifold*, Proc. Nat. Acad. Sci. USA **42** (1956), 359–363.
- [37] P. Seidel *Fukaya Categories and Picard-Lefschetz theory*, EMS Zurich Lect. Adv. Math. (2008).
- [38] P. Seidel, *Homological mirror symmetry for the quartic surface*, Memoirs of the American Mathematical Society **236** (2015), no. 1116,
- [39] P. Seidel, *Vanishing cycles and mutation*, European Congress of Mathematics. Birkhäuser Basel, 2001.
- [40] P. Seidel, *More about vanishing cycles and mutations*, Symplectic geometry and mirror symmetry (Seoul, 2000), 429–465, World Sci. Publ., River Edge, NJ, 2001.
- [41] Y. Takeuchi, *Waldhausen’s classification theorem for finitely uniformizable 3-orbifolds*, Trans. AMS. **328** (1991), no. 1, 151–200.
- [42] H. B. Lawson and M. L. Michelsohn, *Spin Geometry*, Princeton Math. Ser. **38**, Princeton Univ. Press, 1990.
- [43] C. A. Weibel, *An introduction to homological algebra*, Cambridge studies in advanced mathematics **38**.

DEPARTMENT OF MATHEMATICAL SCIENCES
RESEARCH INSTITUTE OF MATHEMATICS
SEOUL NATIONAL UNIVERSITY
KWANAK-RO 1, KWANAKGU, SEOUL 151-747, KOREA
E-mail address: chocheol@snu.ac.kr

CENTER OF MATHEMATICAL SCIENCES AND APPLICATIONS
HARVARD UNIVERSITY, 20 GARDEN STREET
CAMBRIDGE, MA 02138, USA
E-mail address: hhong@cmsa.fas.harvard.edu

RECEIVED MARCH 22, 2015